

CW Operation of SC TESLA Cavities

W. Anders, J. Knobloch, O. Kugeler, A. Neumann, BESSY, Berlin Germany

- BESSY Projects: FEL, STARS
- HoBiCaT Testfacility
- CW \leftrightarrow Pulsed RF
- CW Cryomodule
- CW Coupler Test
- HOM Heating
- Microphonics
- Summary

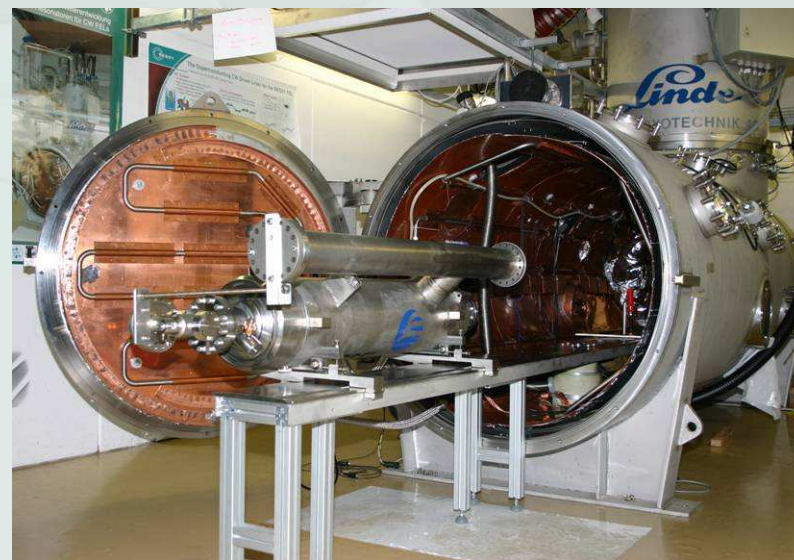

Electron energy	2.3	GeV
RF frequency	1.3	GHz
RF mode	CW	
Cavities/Cryomodules	TESLA type modified	
Number of Modules/Cavities	18 / 144	
Bunch repetition rate	25	kHz



- Test FEL at BESSY for demonstrating cascaded HGHG operation
- Electron Energy 325 MeV
- 20 fundamental cavities 1.3 GHz and 7 harmonic cavities 3.9 GHz
- Field gradient ~ 17 mV/m \rightarrow 23 W cryogenic loss per cavity
- Total cryogenic losses 750 W@1.8 K

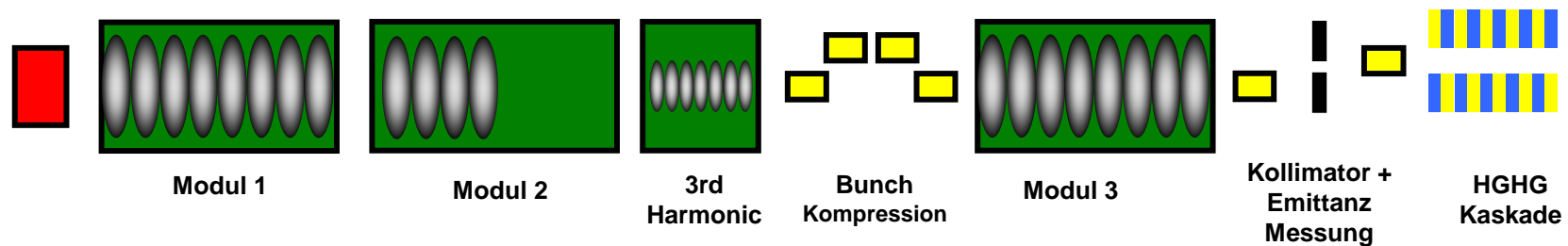

HoBiCaT

A Testfacility for superconducting cavities in CW mode.

The HoBiCaT Test facility include all things you need for measurements of cw-related topics of TESLA type cavities:

- Cryogenics 80 W @ 1.8 K
- Cryostat for two cavities
- Cavities
- Tuner
- CW Transmitter
- Low level electronics



Bunch Structure

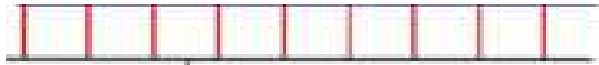

CW FEL operation

bunch spacing: 40 μ s – 10 ms

RF pulse: CW

Beam current: 80 μ A

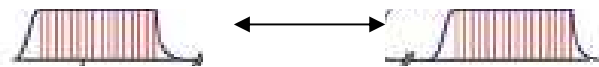

Pulsed operation:

RF pulse: 1 ms

bunch gap: 100 ms

Current in bunch train: 8 mA

	CW	Pulsed
Duty factor	100%	1%
Field gradient	15-20 MV/m	20-35 MV/m
Cryogenic load per cavity	20-30 W	< 1 W
Dynamic cryogenic losses	dominant	average
Loaded Q-value	$\sim 10^8$	$\sim 10^6$
Bandwidth of Cavity	1-30 Hz	100-500 Hz
Lorenz force detuning	weak	strong
Microphonic detuning	dominant	not relevant
Average RF power per Cavity	5 kW	1.5 kW
Peak power per cavity	15 kW	150 kW

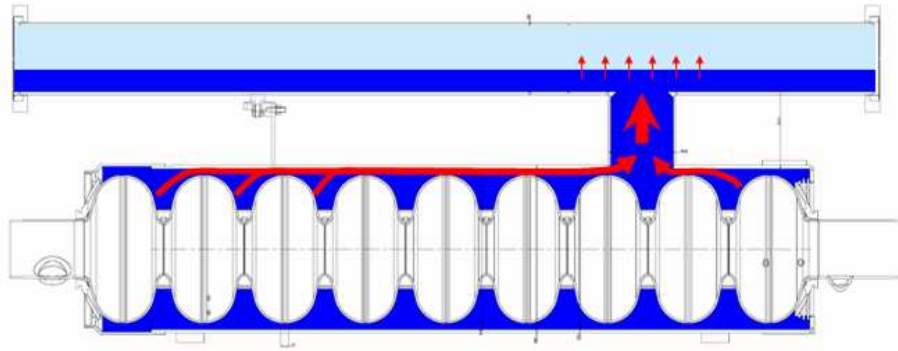

Tesla cavities are operated below λ -point at 2.17 K → better heat conductivity, no film boiling

Helium vaporizing in 2-phase line

In CW operation heat load is 20-30 W/cavity

Limiting bottlenecks for heat conductivity are the vessel at the cavity iris (62cm²) and the chimney:

Chimney: TESLA 23 cm²/BESSY 63 cm²

Experiment: Increasing the heat load by an electric heater → quench at conductivity limit of 1.53 W/cm²

Experiment was performed with TESLA and with BESSY chimney with same result

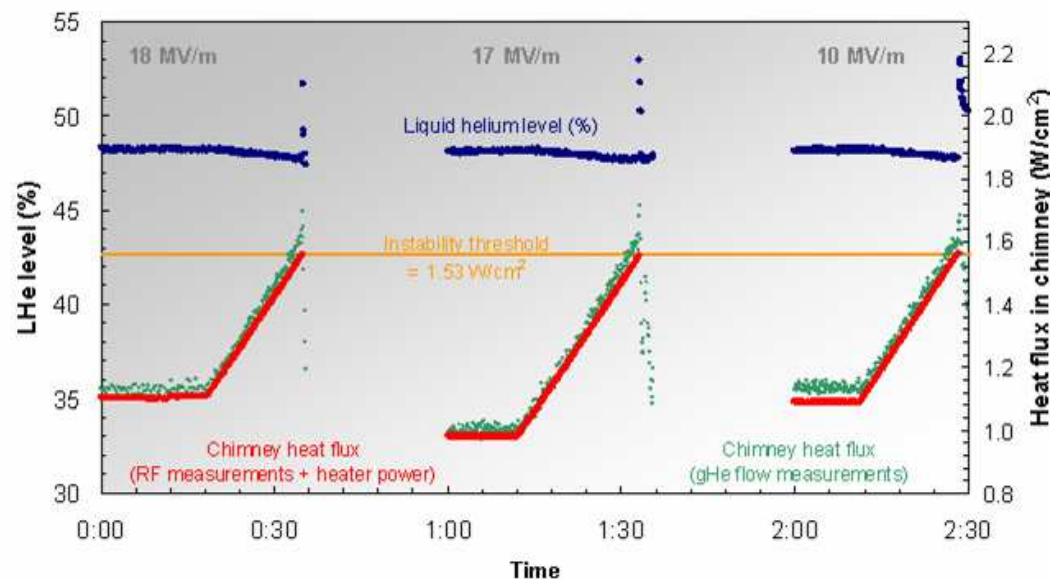

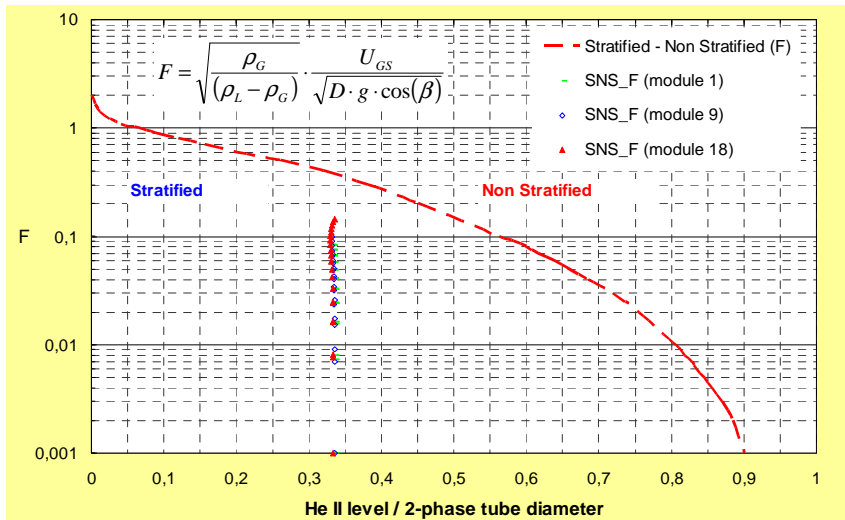

The helium supply line contains two phases of helium:

- liquid helium for the cavity supply
- vaporized helium return gas

To avoid instabilities in the 2-phase line the vapor speed should be below 4 m/s

➔ Increase diameter of 2-phase line and two connections to gas return pipe every module

Calculations show, the BESSY FEL is in the regime of stratified partly wavy helium flow

Calculations by Xian Yu, GSI, Darmstadt

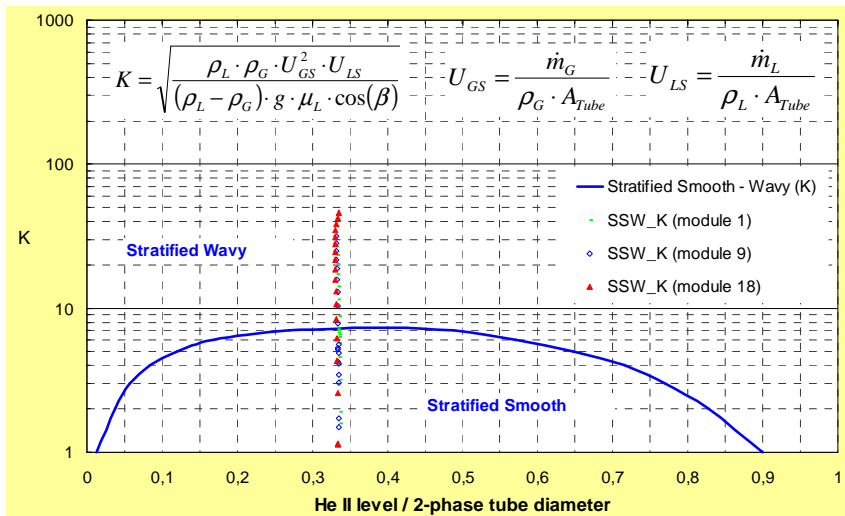

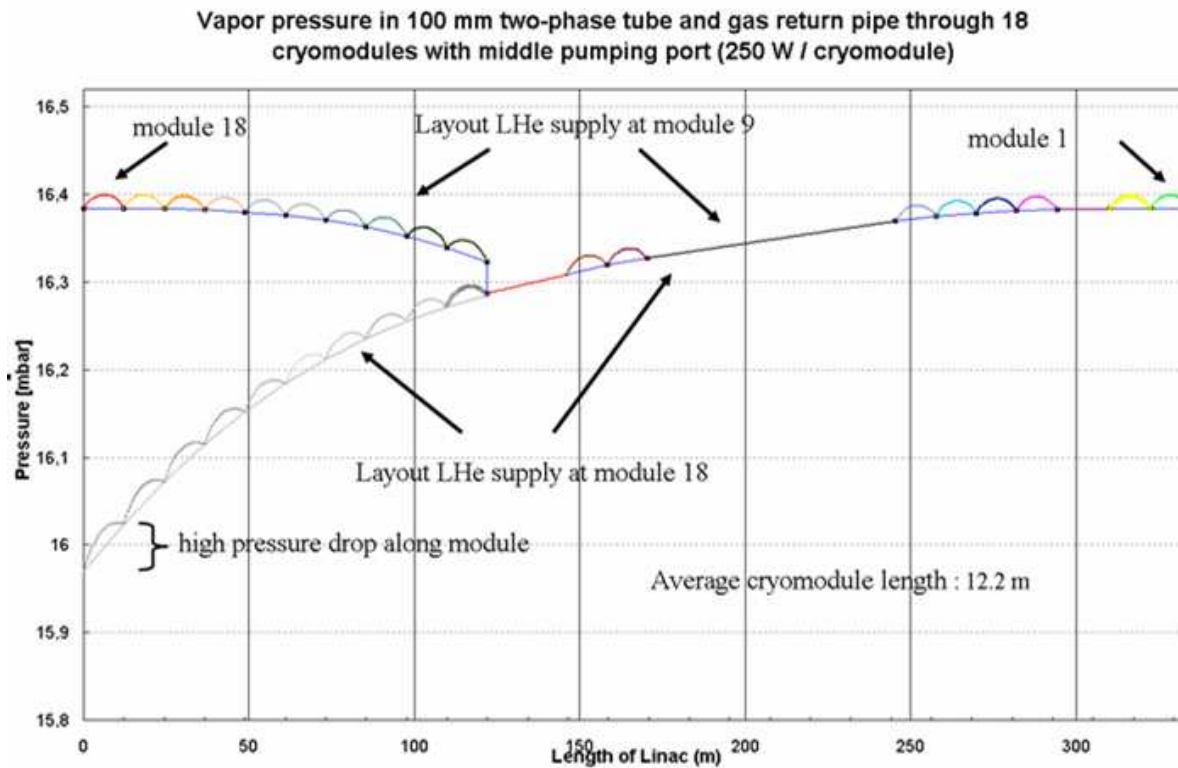

The gas return pipe (GRP) is the mechanical reference of the cryo module

Diameter: 300 mm

Pressure drop is calculated or the BESSY FEL:

1. Connection to cryoplant at the end of the linac
2. Connection to cryoplant in the middle of the linac

➔ Connection at the end causes high pressure drop along first modules

➔ Connection in the middle of the linac uncritical

CW changes on the cryo module

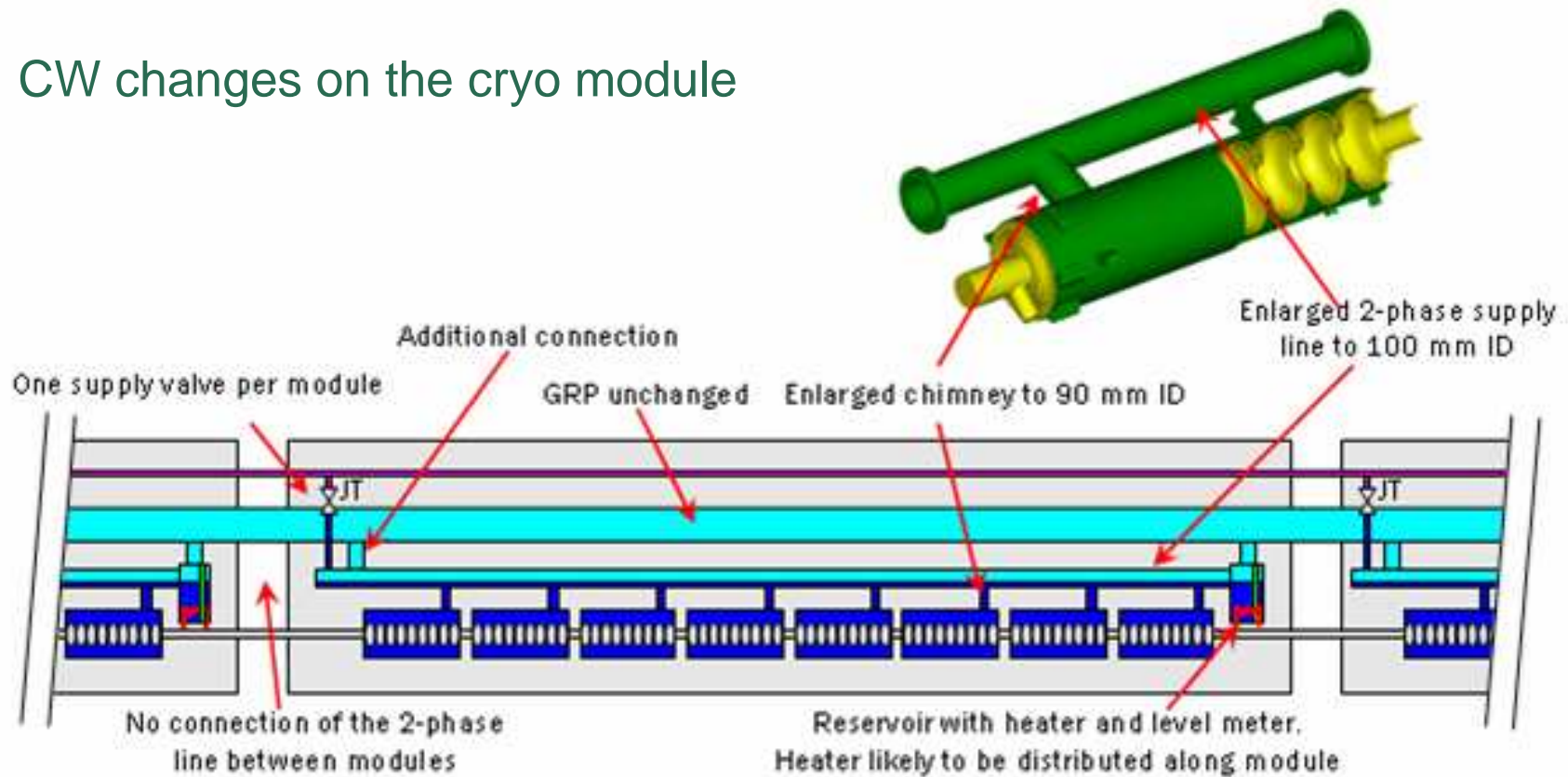

Optimal helium bath temperature

In CW linacs the dynamic losses in a cryomodule of 8 cavities are about 200 W and static losses of about 3 W are negligible.

The dynamic cryogenic losses of a superconducting cavity are inversely proportional to the unloaded quality factor Q_0 . When magnetic shielding is good, the BCS theory is applicable and quality factor is rising to lower temperatures.

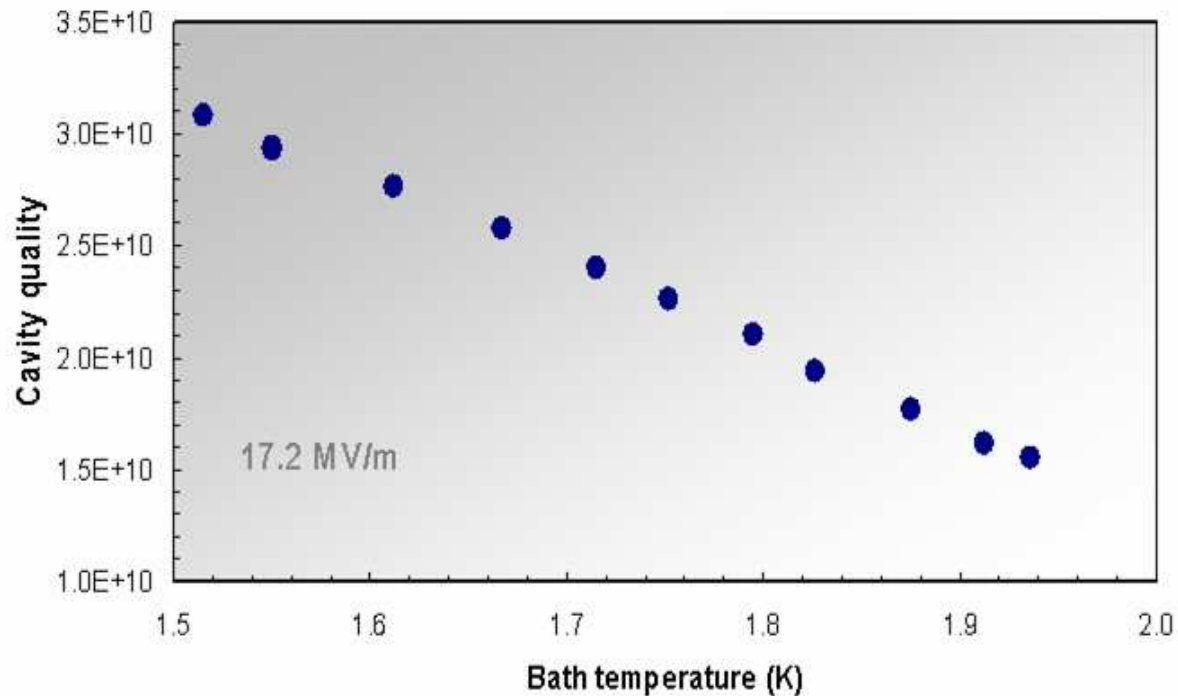

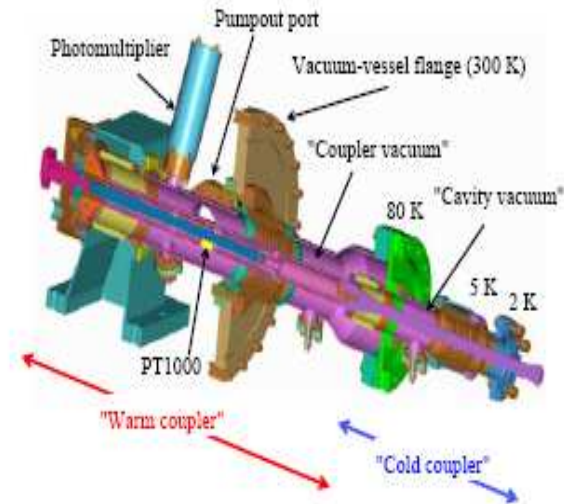

RF coupler was tested under warm and cold conditions.

It was operated into a load (traveling wave) and into shorted wave guide with worst case length.

Bellow at the warm part of the inner conductor is the thermal critical place and has to be cooled by gas flow

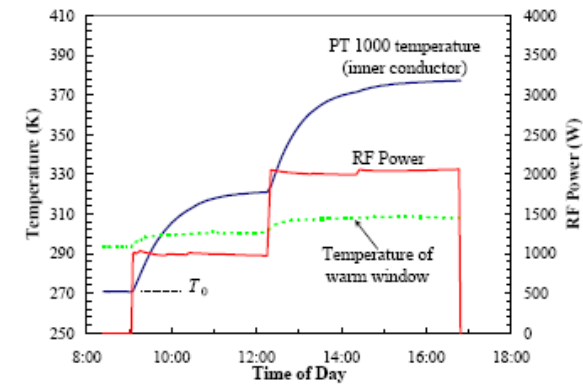

(a)

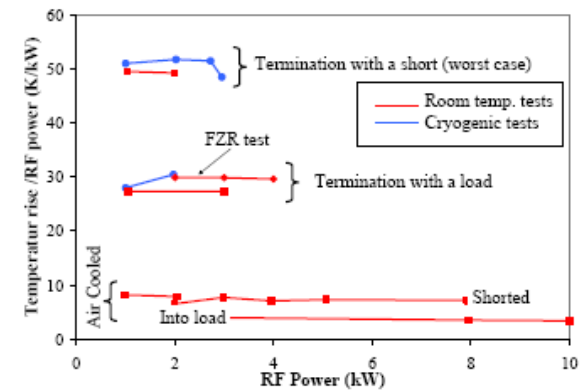

(b)

Heating of HOM feedthroughs

Heating of the ceramics of the HOM feedthroughs causes quench in CW operation

→ Using sapphire with good thermal conductivity instead of ceramics

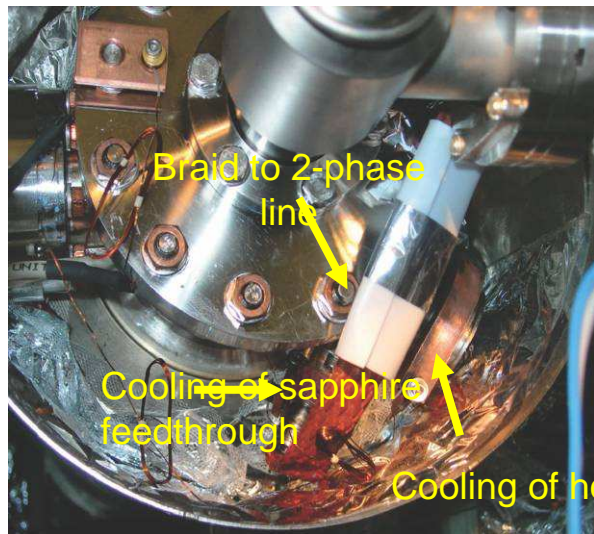
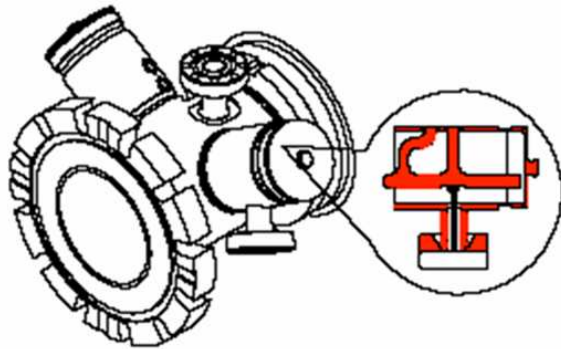

Tests in collaboration with JLAB and DESY

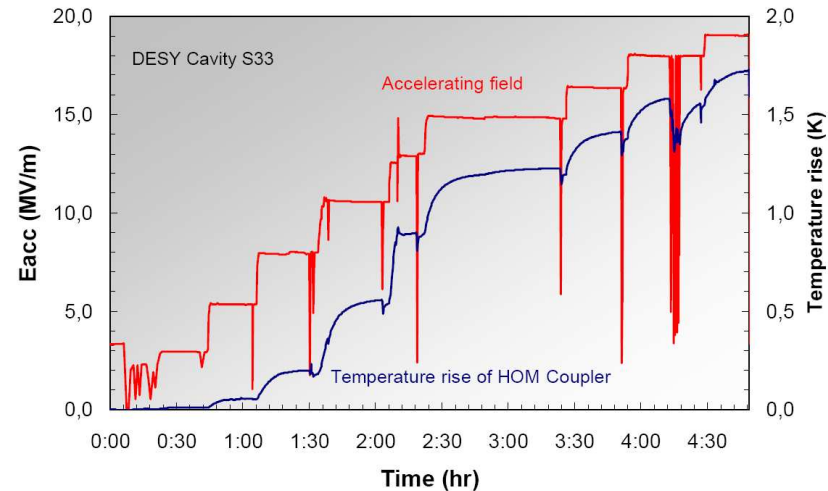

- Bath temperature plays no unexpected role
- Probably cooling by straps to 2PL is not needed (up to 20 MV/m). Still should investigate if cooling can be removed altogether.
- Pickup cables are a significant source of heat! These need a thermal anchor and/or low conductivity cables must be employed
- 20 MV/m (and higher) CW operation should be easily realisable with the new feedthroughs!

Detailed measurements on microphonics have been performed.

- Dominant part below 1 Hz by pressure fluctuations of helium bath even the pressure stability was $\sigma=30\mu\text{bar}@16\text{mbar}$ limited by the resolution of the pressure sensor
- Mechanical resonances 40-200 Hz
- Turbo pump 300 Hz

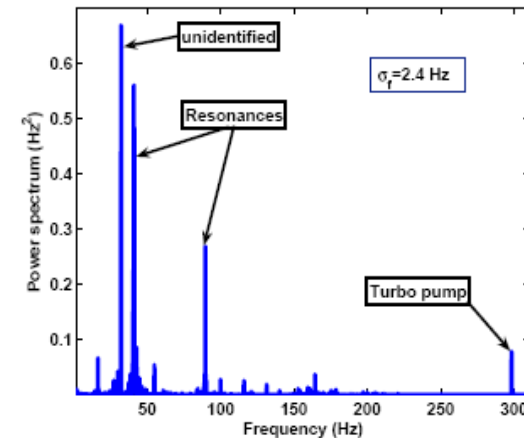

Microphonics spectrum, low frequencies suppressed due to short measuring time

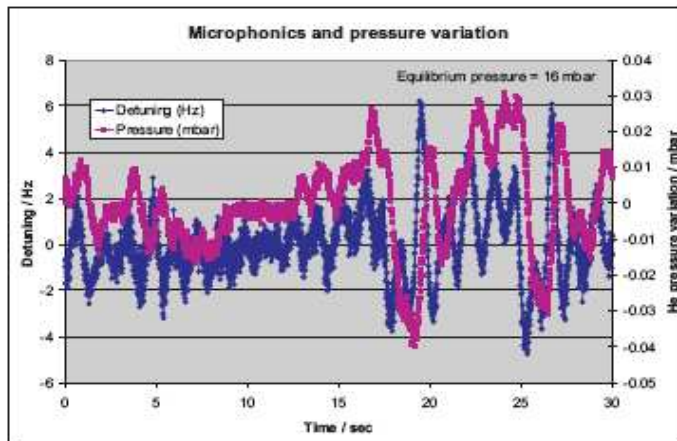

Correlation of helium bath pressure and microphonic detuning

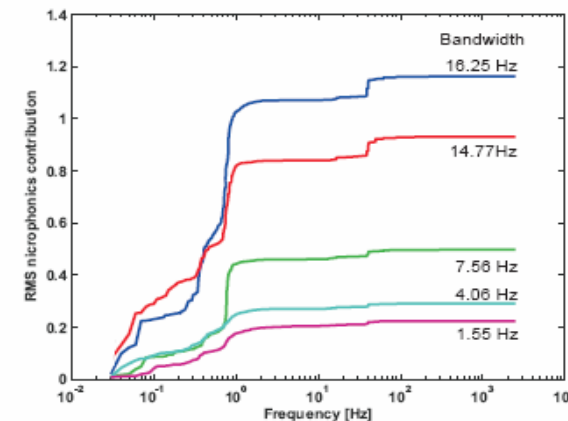

Integrated microphonic spectrum for different cavity bandwidth (open loop)

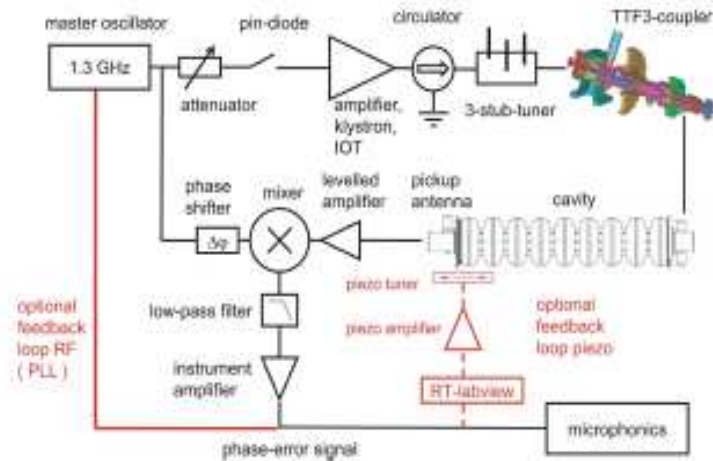

Feedback and feed forward was used to compensate microphonics

A phase detector gives a phase-error signal acting on a piezo tuner

Loop was realized with a LabView Realtime System

Good results for compensating low frequencies up to a few Hertz with a feedback loop (picture)

300 Hz microphonics from the turbo pump and mechanical resonances at 40 Hz and 170 Hz could be compensated using feed forward

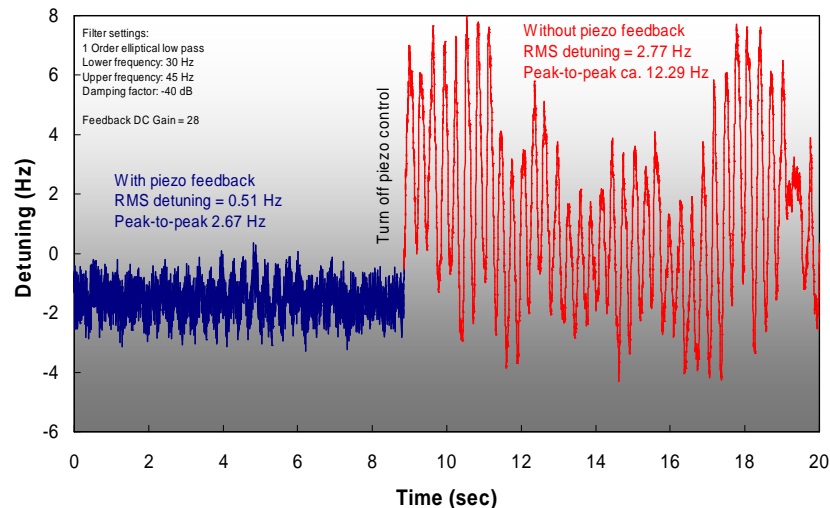

- BESSY Projects were presented
- HoBiCaT Testfacility for SC TESLA Cavities in CW Mode was introduced
- Detailed Measurements on:
 - Design of a CW Cryo Module
 - Optimal Bath Temperature
 - Coupler Test in CW Mode
 - HOM Heating
 - Microphonics and Compensation

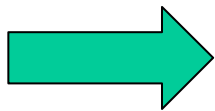

**Solutions on all essential topics to operate
TESLA cavities in CW mode were presented**

Thanks to the BESSY Group, many people from DESY, CEA Saclay, Cornell and Cebaf for their support

Paper TUP40 at SRF conference 15.-19.10.2007 Beijing