



***11<sup>th</sup> European Synchrotron Light Source  
Radio-Frequency Meeting***

**04-05 October 2007**

**Synchrotron SOLEIL, Gif-sur-Yvette**

**COMMISSIONING AND FIRST  
OPERATIONAL EXPERIENCE  
WITH THE SOLEIL RF SYSTEMS**

**P. Marchand**



## Operational experience with the BO RF system

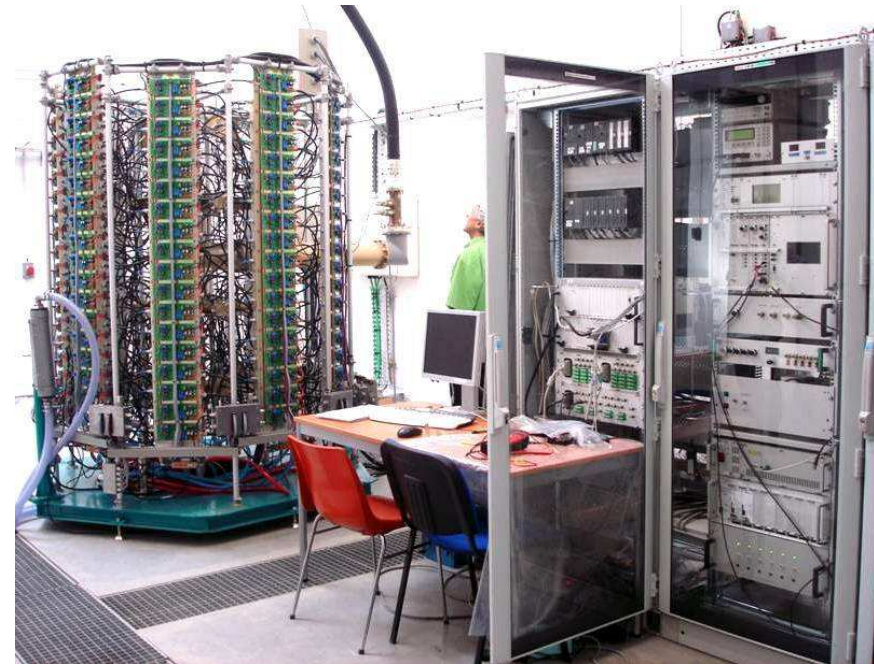
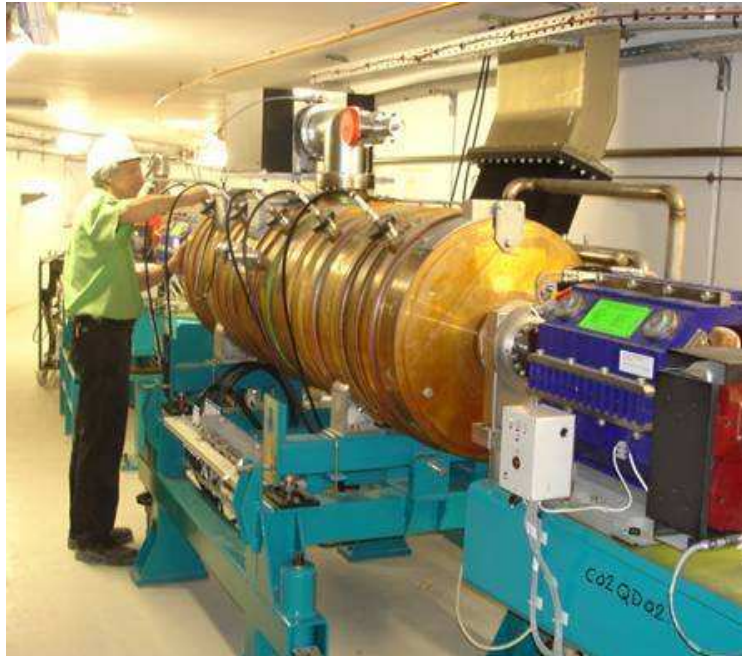

The BO RF plant was commissioned mid 2005.

Up to date, after ~ 7 000 running hours, only a single trip in operation, due to a human mistake → **Don't play with the equipment during the operation !**

**The 35 kW solid state amplifier has proved to be very reliable :**

- 4 (out of 147) modules had a failing → bad soldering (3) + 1 filter (**0 transistor failure !**)
- In any case, that did not affect at all the operating conditions and could be quickly repaired during scheduled machine shutdowns.



## Commissioning of the SR RF



As scheduled for the first year of operation, with  $I_{\text{beam}} < 300$  mA and a reduced number of insertion devices, one half of the SR RF system (CM1, 2 amplifiers, the associated cryogenic plant, control and LLRF systems) was commissioned, during summer 2006.

The goal of storing up to 300 mA of stable beam, using a single CM, was quickly achieved.

**At first, without the RF feedback, the cavity was slightly detuned in order to cope with the Robinson instability, at the expense of ~ 10 kW extra reflected power.**

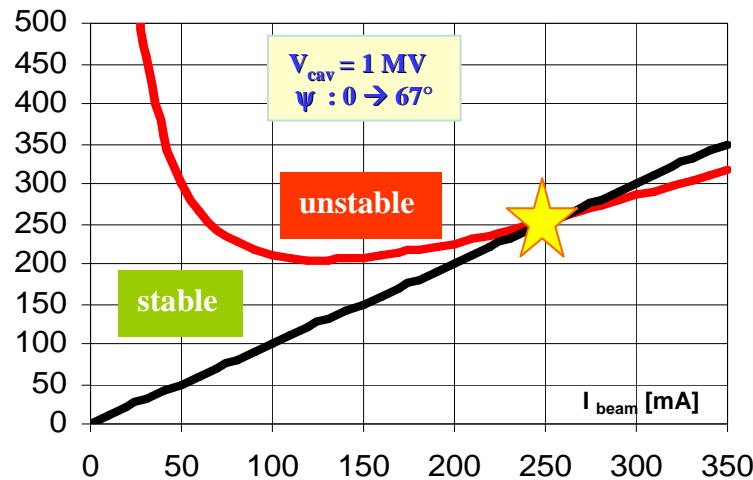

$\psi = \psi_{\text{opt}} (P_r \text{ min}) \rightarrow$  beam lost at 230 mA

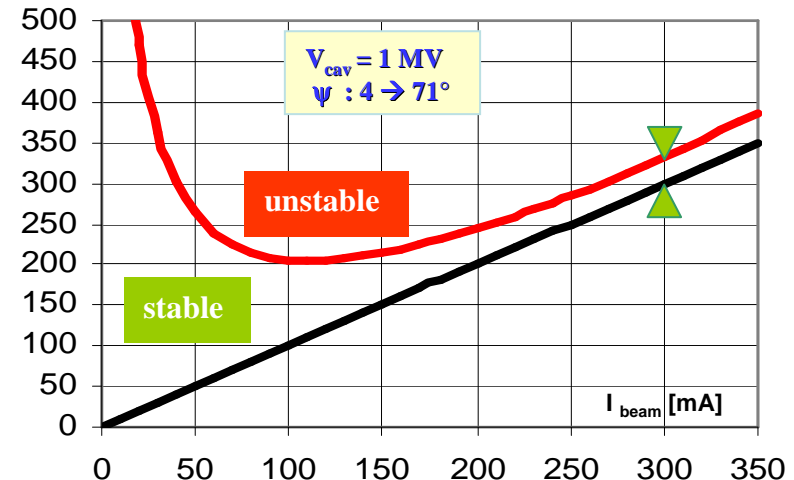

$\psi = \psi_{\text{opt}} + 4^\circ \rightarrow$  stable up to 300 mA

**Later on, we have commissioned the RF feedback, which enabled to store up to 300 mA stable beam without any tuning offset, hence saving ~ 10 kW of reflected power.**



# Commissioning of the SR RF

RF power required per cavity ( $P_i$ ,  $P_r$ ) vs  $I_{\text{beam}}$  at cst voltage of 1 MV / cav

No RF feedback,  $\psi = \psi_{\text{opt}}(I_b) + 4^\circ$

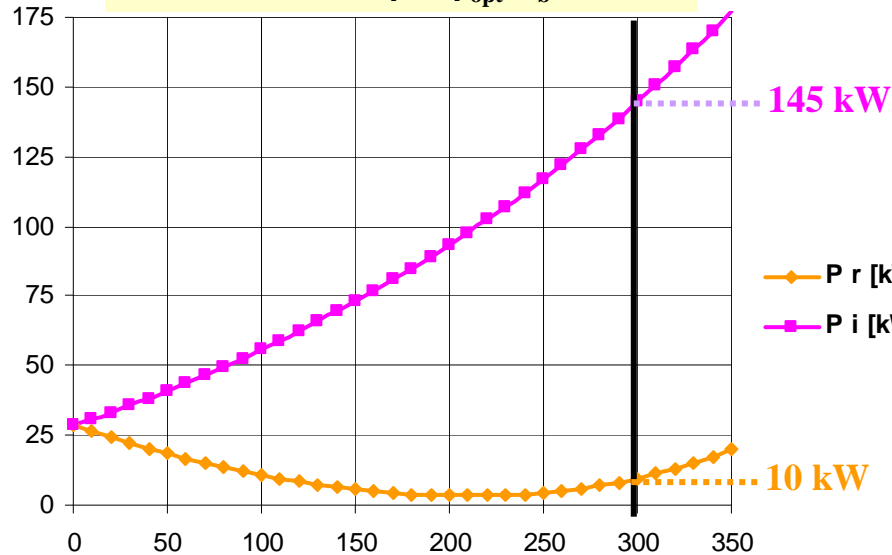

With RF feedback,  $\psi = \psi_{\text{opt}}(I_b)$

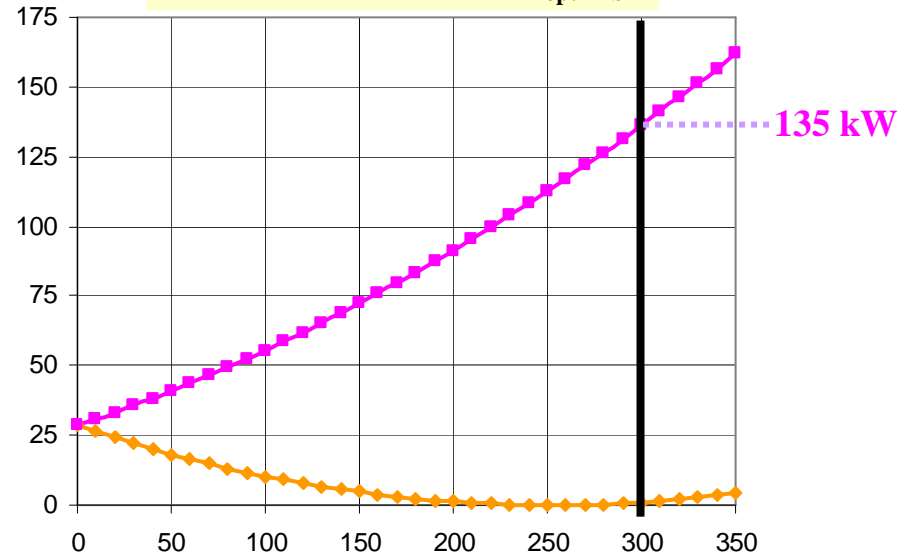

Under these conditions, at cst  $V_{\text{cav}} = 1$  MV, the tuning loop is continually active, compensating for the reactive beam loading either partially (no RF feed-back) or fully (with RF feed-back)

→ Frequency changes of  $\sim 4$  kHz, about 10 000 motor steps, required at each injection.

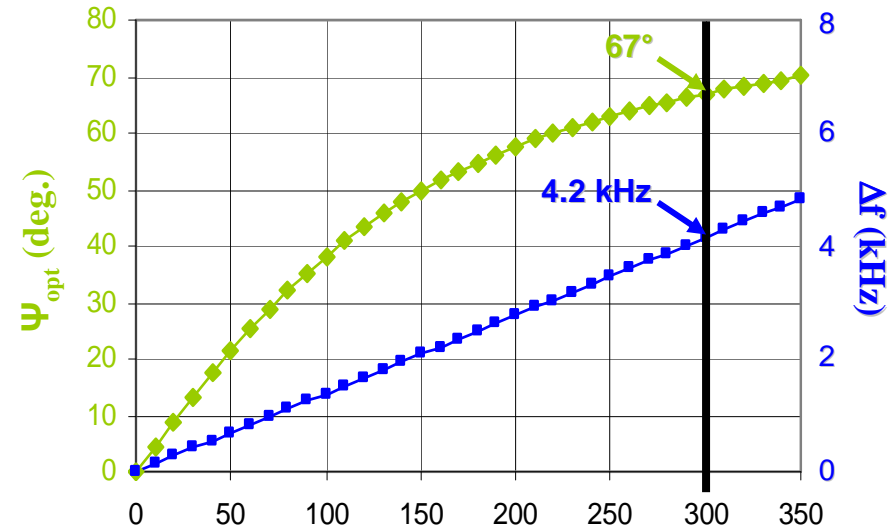



## Commissioning of the SR RF



### Injection at constant tuning

Considering the difficulties encountered on Super-3HC at ELETTRA with a similar tuning system, which happened to get stuck after ~ 50 millions of motor steps, it was proposed to **operate at constant tuning during the injection**, in order to use the tuners more sparingly.

**Injecting at constant tuning requires a ramping of  $V_{cav}$** ; otherwise too large  $P_r$  at low current (red plot).

$V_{cav}$  : 1.4 MV cst,  $\psi = 60^\circ$

$V_{cav}$  : 1  $\rightarrow$  1.4 MV,  $\psi = 60^\circ$

$V_{cav}$  : 0.65  $\rightarrow$  1.4 MV,  $\psi = 60^\circ$

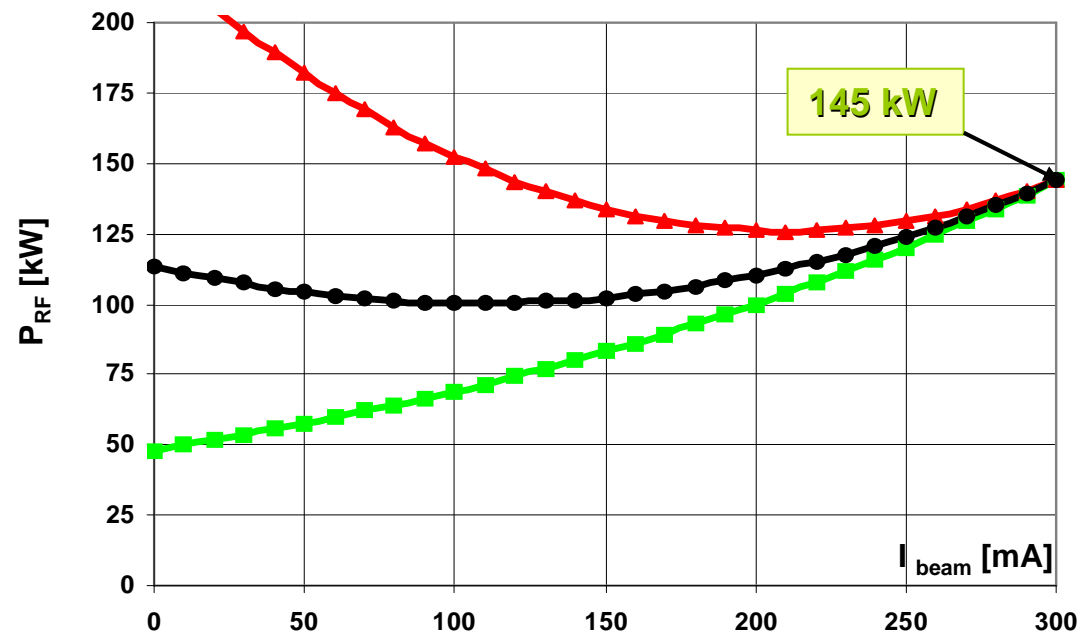

Ramping  $V_{cav}$  from 650 kV at 0-current, up to 1.4 MV at 300 mA, with fixed tuning angle,  $\psi = 60^\circ$ , allows to maintain  $P_r < 50$  kW and  $P_i \sim 145$  kW (green plot).



**Energy and phase acceptance at low RF voltage ?**



## Commissioning of the SR RF



### Injection at constant tuning

At  $V_{RF}$  as low as 1.3 MV (650 kV / cav), E &  $\Phi$  acceptance strongly reduced

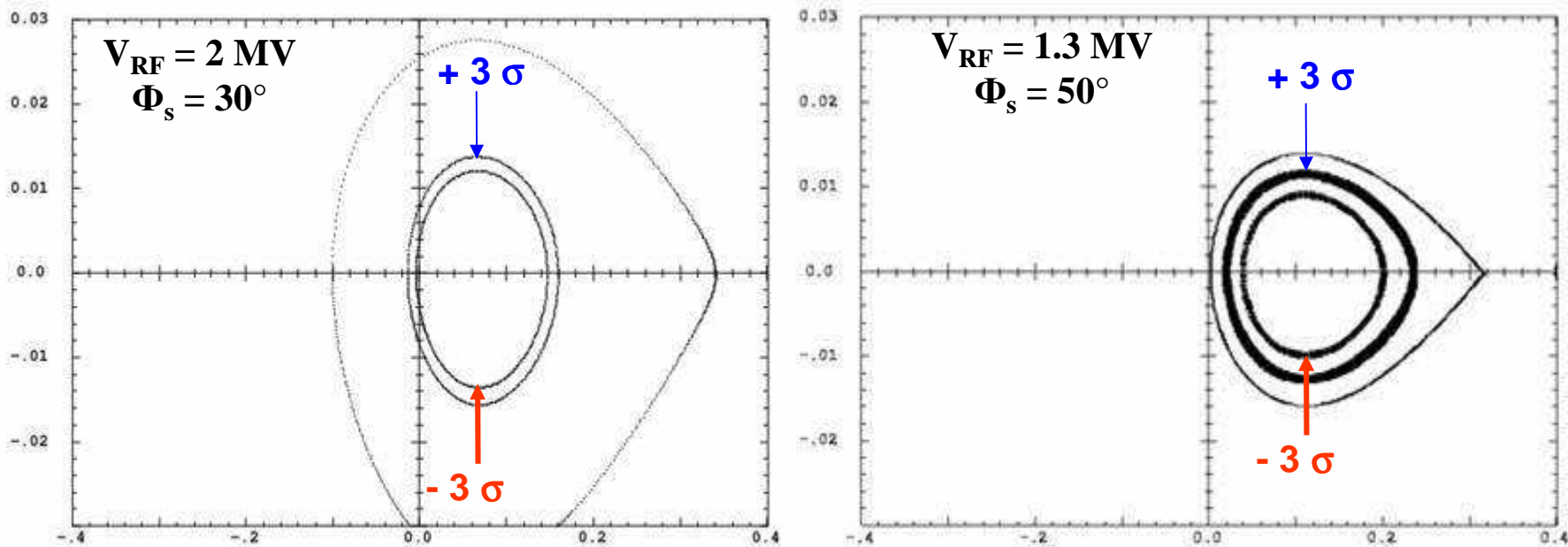

The experience demonstrated that it remains tolerable : injection efficiency nearly unaffected while keeping  $V \sin \Phi$  cst :  $V(I_b)$  and  $\Phi(V)$ , numerically controlled via the PLC

Precise control of  $\Phi(V)$  required for operating with the multibunch transverse feedback

Constant tuning mode routinely used in operation ; easy switching from constant to variable tuning mode (for run dedicated to machine R&D  $\rightarrow$  free control of  $V_{RF}$ )



## Commissioning of the SR RF



### Injection at constant tuning – Robinson stability

$$V_{\text{cav}} : 0.65 \rightarrow 1.4 \text{ MV}, \psi = 60^\circ$$

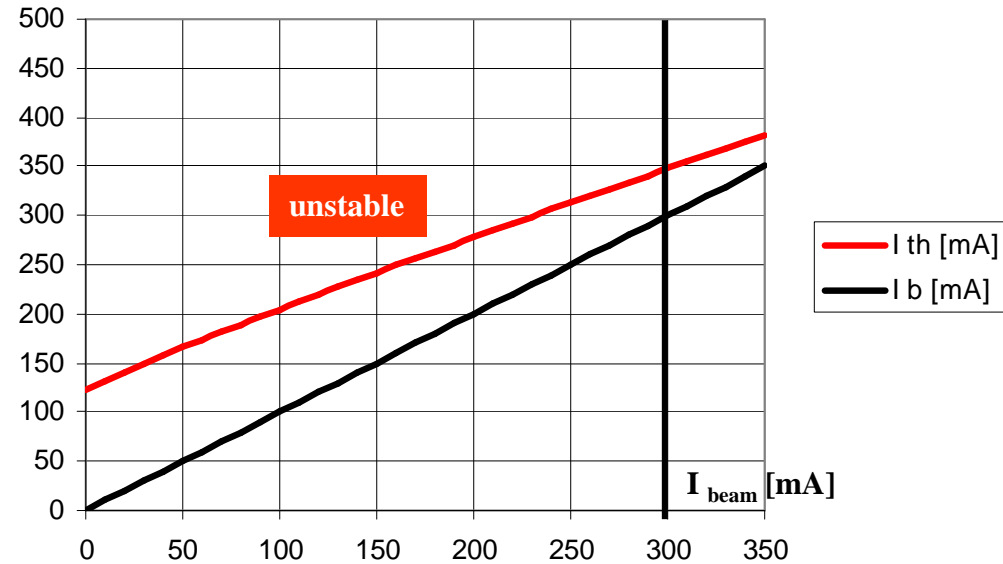

Large stability margin even without RF feedback



## Operational experience with the cryomodule (CM1)



CM1 had been RF conditioned with full reflection ( $I_{\text{beam}} = 0$ ) up to 200 kW per coupler, at CERN and then up to 80 kW, once installed in the SOLEIL SR (always kept under HUV).

Re-conditioning with beam went quite smoothly : a few coupler vacuum trips, at first when reaching  $P > 150$  kW ; further conditioning likely would be required for operating at such power level ; however, with proper settings,  $P < 145$  kW @ 300 mA with a single CM, which is more demanding than 500 mA with 2 CMs.

No evidence of HOM excitation : up to 300 mA, power dissipation in the HOM loads always negligible & residual beam phase oscillations  $< 0.1^\circ$

Taking care of using the cavity tuners sparingly → cst tuning operation as much as possible  
+ additional diagnostic → rev counter for early detection of signs heralding a sticking

Indeed that allowed us to detect a malfunctioning (→ report by P. Bosland)





## Status of the second cryomodule (CM2)



- Under fabrication (by ACCEL GmbH)
- Two cavities successfully tested in vertical cryostat at CERN (at first Nb sputtering for cav1 and at second try for cav2) → CM2 is being assembled
- Complete CM2 (cryo + RF power) tests scheduled for beginning 2008 at CERN
- Installation and commissioning in SOLEIL SR → May 2008 shut-down

### SOLEIL CM2 cavities : $Q_0$ vs $E_{acc}$

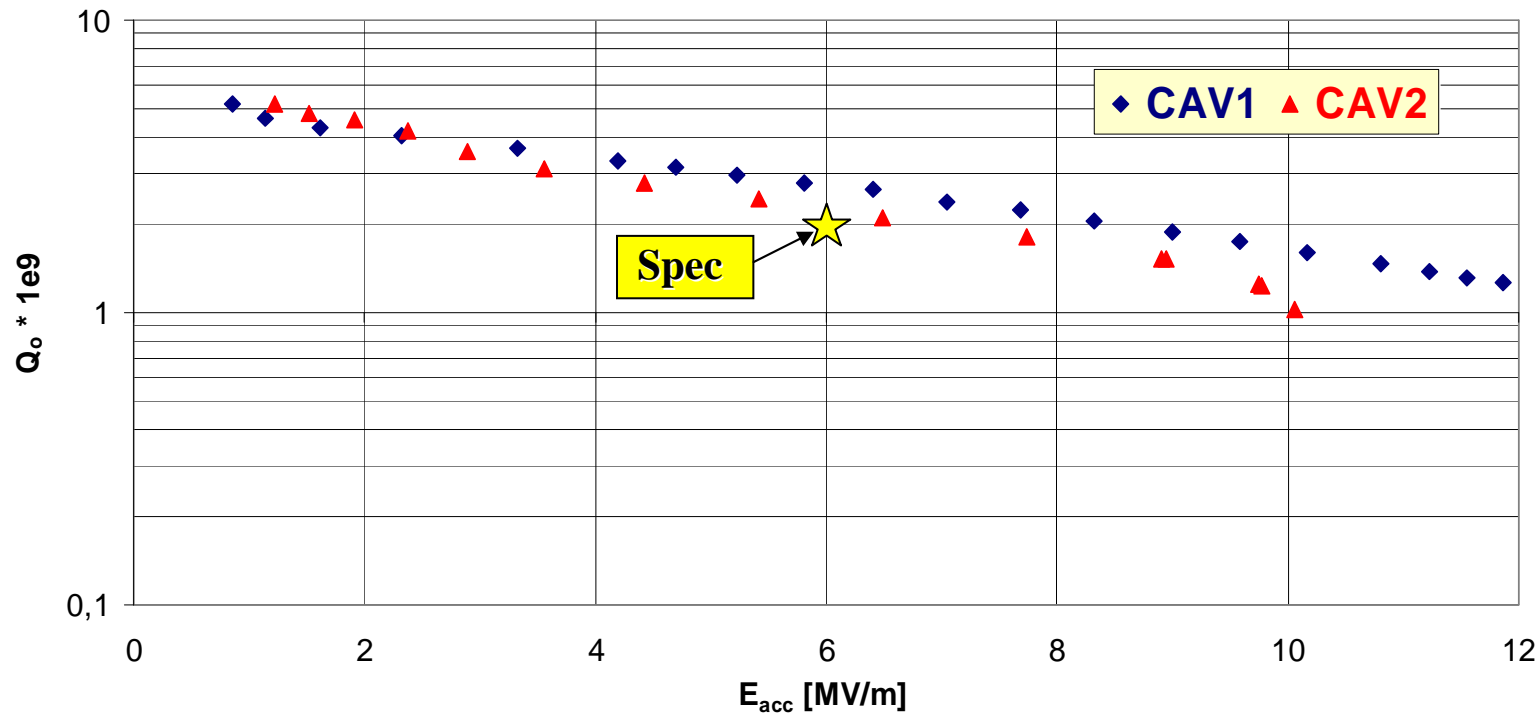



## Operational experience with the cryogenic plant



At the beginning of the commissioning, difficulties were encountered with LHe feeding and pressure instabilities inside the cavity He tank, due to an unexpected thermal load on a pipe of the cryogenic valve box.

This was solved after bringing in slight modifications on the cryogenic valve box. The system has then become very reliable and the pressure variations could be kept below  $\pm 2$  mbar, namely  $\pm 0.1^\circ$  in phase.



**Forthcoming upgrades** → improve the autonomy

- Process modification → take profit of the autonomy provided by the Dewar
- UPS extension to all the Cold-box components
- Cold-box dedicated water-cooling



## Operational experience with the RF power amplifiers



- The two 180 kW solid state amplifiers for CM1 have demonstrated a good reliability in operation : after ~ 6 000 running hours, only two trips, due to human mistakes (cable pull out by accident and a wrong manipulation)
  - Although not perturbing for the operation, 41 (out of 1450) modules have suffered from a transistor failure; for 10 of them, it was the result of a circulator load failing → Thermal grease has been added
  - **Failure rate of ~ 3 % / year** → pessimistic since it includes part of the *infant mortality* (the failure rate is still decreasing with time) → longer running periods are required to find out the *actual MTBF*
  - **100 available spare modules** → turn over : 50 usable in house while 50 under repair
- Accidental event out of the operation time :  
21 modules damaged at once due to strong transients, induced when testing the new digital I/Q feedback (10 MHz BW → too fast to be detected by the interlock system)  
→ need for a filter with BW of ~ 100 kHz !!





## RF power amplifiers : forthcoming



- Concerning the amplifiers 3 and 4 for the CM2, 6 of the 8 required 45 kW towers are already completed → **Power tests of the 2 complete amplifiers by the end of 2007**
- **Investigations of other suitable transistors are going on** : 2 samples of the *BLF369*, newly developed by Philips, have been tested and **the results are quite promising**; a 2.5 kW unit (8 modules) is being built for long duration power tests
- **R&D** : - upgrades of the 350 MHz amplifiers
  - @ other frequencies : 500 MHz , 476 MHz (2 x 40 kW for LNLS)
  - 90 x 15 kW @ 1.3 GHz for “ARC-EN-CIEL”
- **Collaboration agreement with the ESRF under preparation** → need for 54 x 50 kW



# Amplifier control via the $\mu$ controller Transistor currents, $P_i$ and $P_r$ for a tower



micro-rf
[-] [x]

		D1		D2		D3		D4		D5		D6		D7		D8		D9		D10		H		
		<input checked="" type="checkbox"/> Preampli	<input type="checkbox"/> Preampli	<input checked="" type="checkbox"/> Preampli	<input type="checkbox"/> Preampli	<input checked="" type="checkbox"/> Preampli	<input type="checkbox"/> Preampli	<input checked="" type="checkbox"/> Preampli	<input type="checkbox"/> Preampli	<input checked="" type="checkbox"/> Preampli	<input type="checkbox"/> Preampli	<input checked="" type="checkbox"/> Preampli	<input type="checkbox"/> Preampli	<input checked="" type="checkbox"/> Preampli	<input type="checkbox"/> Preampli	<input checked="" type="checkbox"/> Preampli	<input type="checkbox"/> Preampli	<input checked="" type="checkbox"/> Preampli	<input type="checkbox"/> Preampli					
<span style="color: red;">OFF</span> T1		4.80	4.70			4.50	4.40			4.70	4.70			4.40	4.40			4.80	4.50					M0
<span style="color: red;">OFF</span> T2		6.50	6.40	6.30	6.20	6.10	6.20	6.10	6.10	6.20	6.20	6.10	6.20	5.90	5.80	6.10	6.00	6.00	6.00	5.90	5.80			M1
<span style="color: red;">OFF</span> T3		6.20	6.20	6.20	6.20	6.30	6.40	0.40	6.30	6.10	6.10	6.20	6.10	5.80	5.80	5.80	5.80	6.00	6.00	5.90	5.90			M2
<span style="color: green;">ON</span> T4		6.30	6.30	6.20	6.20	6.10	6.10	6.20	6.20	6.10	6.10	6.00	6.20	5.70	5.70	5.90	5.90	5.90	5.80	6.20	5.90			M3
		6.10	6.10	6.30	6.20	6.10	6.20	6.30	6.20	6.00	6.00	6.10	6.20	6.00	5.90	6.00	6.00	6.10	6.20	6.20	6.20			M4
		6.20	6.20	6.30	6.20	6.20	6.20	6.10	6.10	6.10	5.90	6.10	6.00	5.80	5.90	5.90	5.90	6.00	6.00	5.90	6.00			M5
<input type="text" value="7.20"/> I <sub>max</sub>		6.20	6.20	6.20	6.20	6.00	6.10	6.00	6.00	5.80	5.90	6.30	6.30	5.80	5.60	6.10	6.00	6.10	6.10	5.90	6.20			M6
<input type="text" value="1.00"/> I <sub>min</sub>		6.30	6.20	6.20	6.30	6.00	6.00	6.30	6.30	6.30	6.20	6.20	6.30	6.00	5.70	5.70	6.00	6.10	6.00	5.80	5.90			M7
<input type="text" value="0.50"/> P <sub>r</sub>		6.20	6.20	6.00	6.10	6.20	6.20	6.10	6.30	6.00	6.00	6.20	6.40	5.90	5.80	6.20	6.10	6.10	6.10	5.90	5.90			M8
<input type="text" value="0.50"/> Delta		1.04	0.10	1.08	0.12	1.10	0.12	1.12	0.14	1.06	0.26	1.12	0.28	1.12	0.18	1.06	0.22	1.12	0.22	1.06	0.14			Pi/Pr
<input type="checkbox"/> Delta		1.14	0.14	1.26	0.12	1.08	0.08	1.02	0.08	0.94	0.14	1.08	0.14	1.18	0.16	1.12	0.16	1.14	0.18	1.14	0.22			Pi/Pr
D0		6.10	5.90	5.80	5.90	6.10	6.10	6.00	6.00	5.90	5.90	5.50	5.50	6.10	6.10	6.20	6.10	5.80	6.00	6.00	6.10			M8
<span style="background-color: red; color: white;">0.00</span> <span style="background-color: red; color: white;">0.00</span>		6.10	6.10	6.00	6.00	6.10	6.10	6.20	6.20	6.10	6.20	5.80	5.90	5.90	5.90	5.90	6.00	6.00	6.00	6.00	6.10			M7
<span style="background-color: red; color: white;">0.00</span> <span style="background-color: red; color: white;">0.00</span>		6.20	6.30	6.30	6.30	6.10	6.10	6.10	6.20	5.70	5.70	6.10	5.90	6.30	6.20	6.10	6.10	6.20	6.10	5.90	5.80			M6
<span style="background-color: red; color: white;">0.00</span> <span style="background-color: red; color: white;">0.00</span>		5.90	5.90	6.00	5.90	6.10	6.00	5.90	6.00	5.90	5.70	6.10	6.20	6.10	6.10	6.10	6.10	6.00	5.80	5.90	5.90			M5
		6.10	6.00	6.00	6.20	5.90	5.90	6.00	6.00	5.80	5.90	5.70	5.90	6.00	6.00	6.40	6.30	6.20	6.10	5.70	5.70			M4
		6.10	6.20	6.30	6.30	6.10	6.20	6.10	6.30	5.80	5.80	6.20	6.10	6.10	6.00	6.10	6.10	5.70	5.80	6.20	6.00			M3
		6.00	6.20	6.00	6.10	6.20	6.30	6.00	6.00	5.90	5.90	6.40	6.50	5.80	5.70	6.40	6.40	6.20	6.10	5.80	5.80			M2
		2.30	2.30	6.20	6.30	6.00	6.00	6.10	6.10	5.90	5.90	5.90	5.50	5.90	5.80	6.00	6.10	6.20	6.20	6.00	6.10			M1
						4.50	4.50			4.60	4.50			4.60	4.50			4.80	4.60					M0
		<input type="checkbox"/> Preampli	<input checked="" type="checkbox"/> Preampli	<input type="checkbox"/> Preampli	<input checked="" type="checkbox"/> Preampli	<input type="checkbox"/> Preampli	<input checked="" type="checkbox"/> Preampli	<input type="checkbox"/> Preampli	<input checked="" type="checkbox"/> Preampli	<input type="checkbox"/> Preampli	<input checked="" type="checkbox"/> Preampli	<input type="checkbox"/> Preampli	<input checked="" type="checkbox"/> Preampli	<input type="checkbox"/> Preampli	<input checked="" type="checkbox"/> Preampli	<input type="checkbox"/> Preampli	<input checked="" type="checkbox"/> Preampli	<input type="checkbox"/> Preampli	<input checked="" type="checkbox"/> Preampli			B		

**AQUISITION**

ON

Pi T1 = 20.38kW   Pi T2 = 20.08kW   Pi T3 = 21.18kW   Pi T4 = 21.98kW

Pr T1 = 5.76kW   Pr T2 = 5.12kW   Pr T3 = 3.04kW   Pr T4 = 3.20kW

Pi Amp2 = 83.6kW   Pr Amp2 = 17.1kW   P Alim2 = 220.9kW

MA AMPLI
ARRET AMPLI

STATS

MESSAGES
CONFIG
GRAPHES
COPIER
SAUVE IMG
SAUVE DATA
IMPRIMER
QUITTER



## Amplifier control via the $\mu$ controller Transistor current distribution

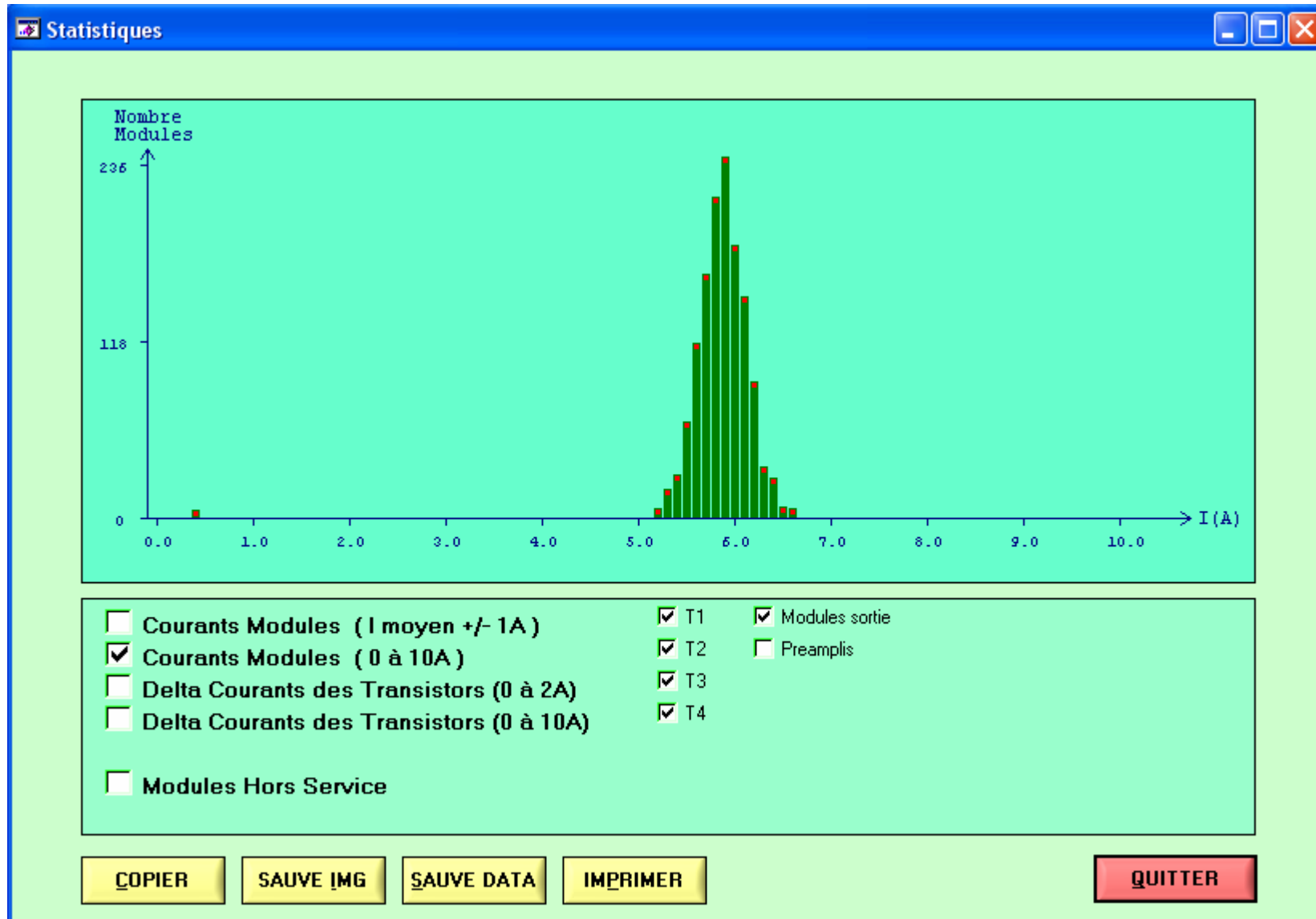



## Amplifier control via the $\mu$ controller Transistor current distribution

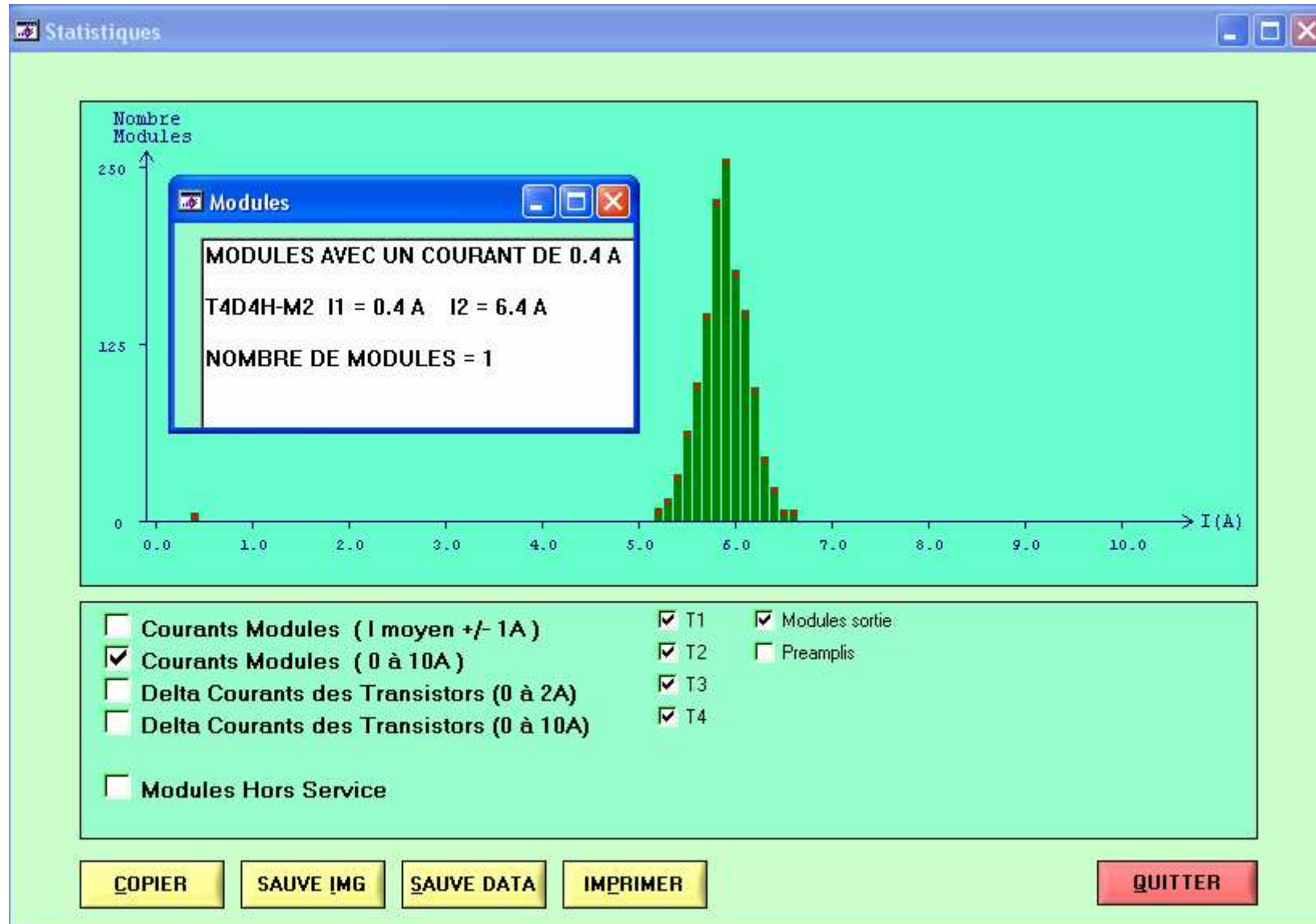



# Amplifier control via the $\mu$ controller

## Single module currents vs time + tower Pi & Pr

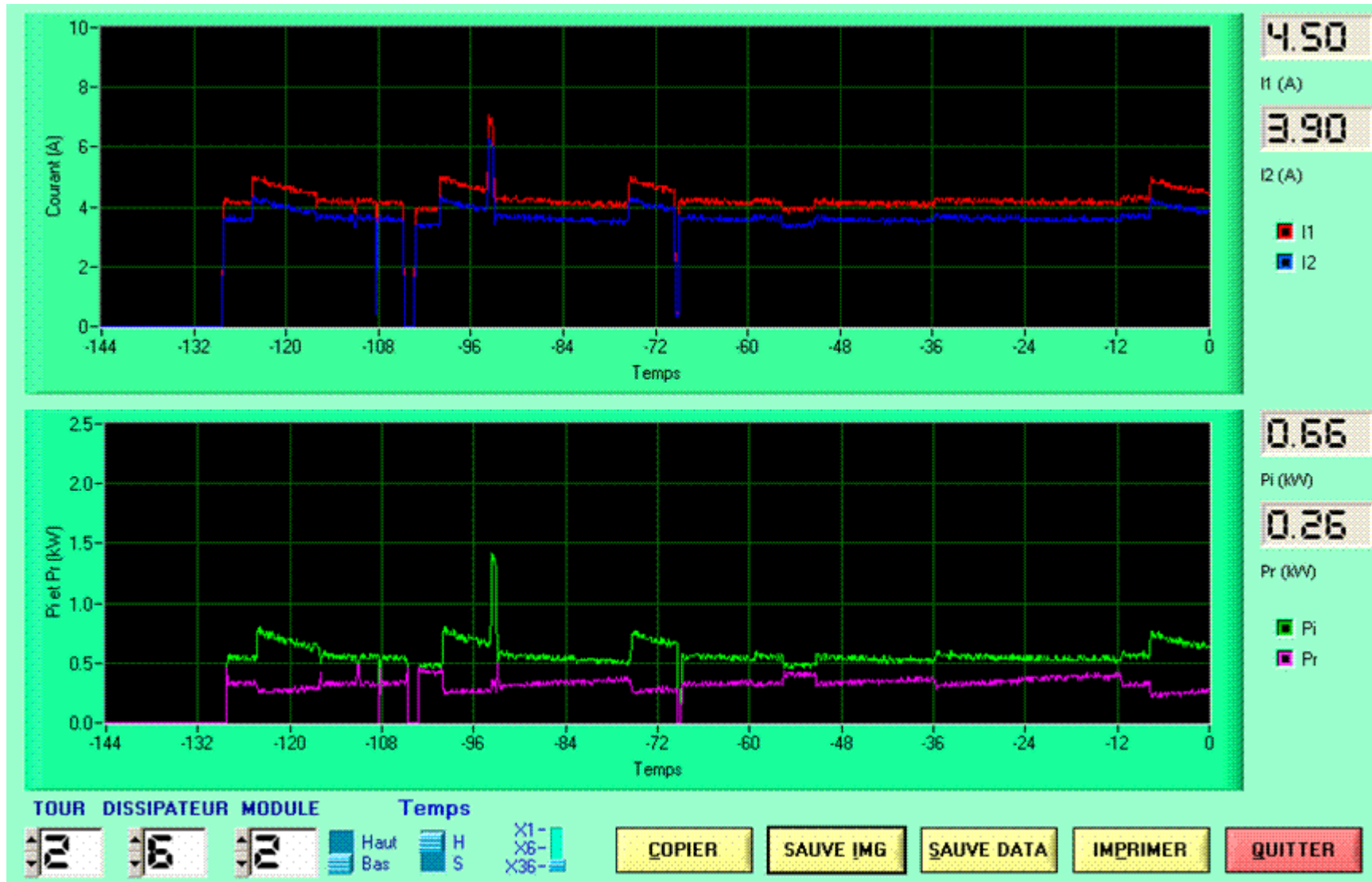



# Operational experience with the LLRF

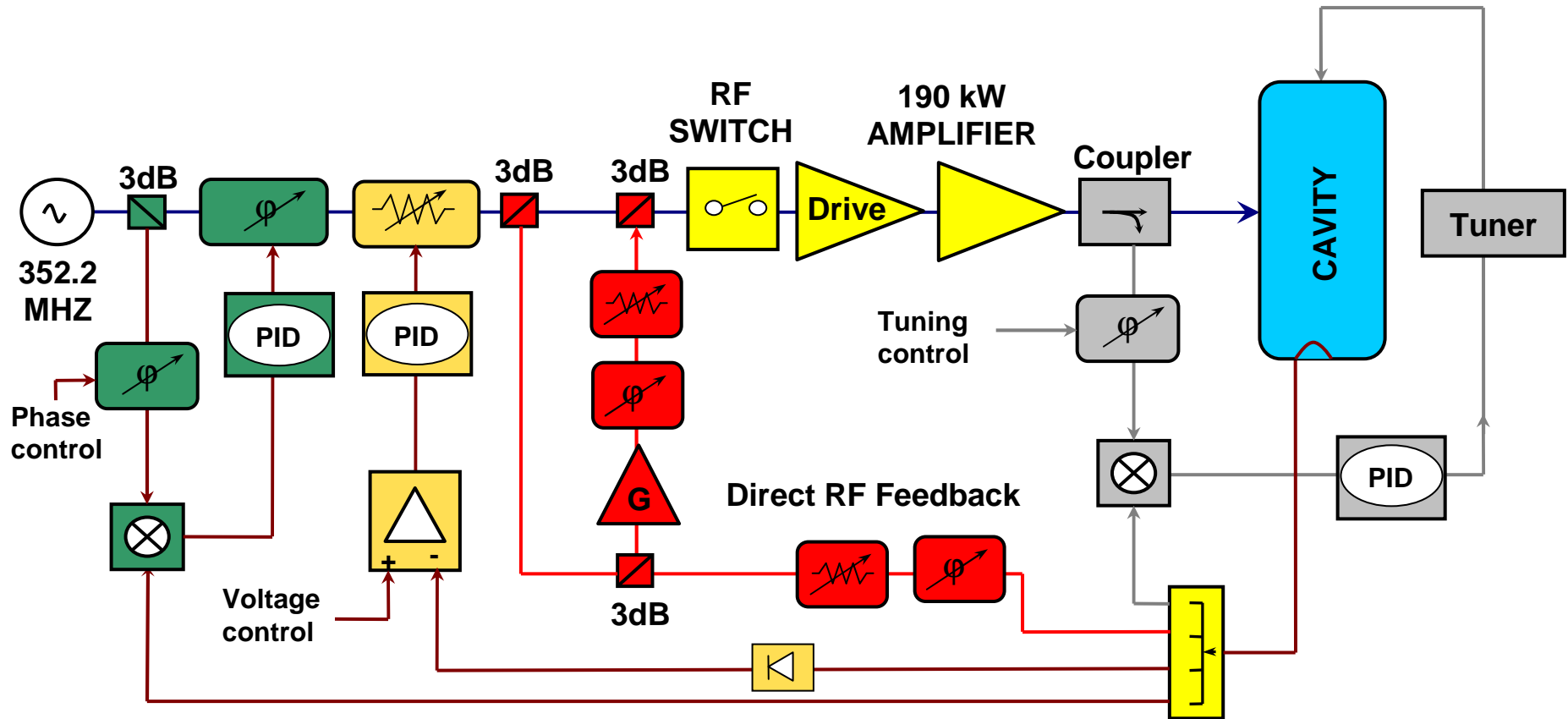

**Without RF feedback** :  $\pm 0.5\%$  in amplitude and  $0.15^\circ$  in phase  
**With RF feedback** :  $\pm 0.1\%$  in amplitude and  $0.05^\circ$  in phase  
 Measured residual beam phase oscillations  $< 0.1^\circ$

- Phase loop
- Amplitude loop
- Frequency tuning loop
- Direct RF feedback



## Fast digital LLRF

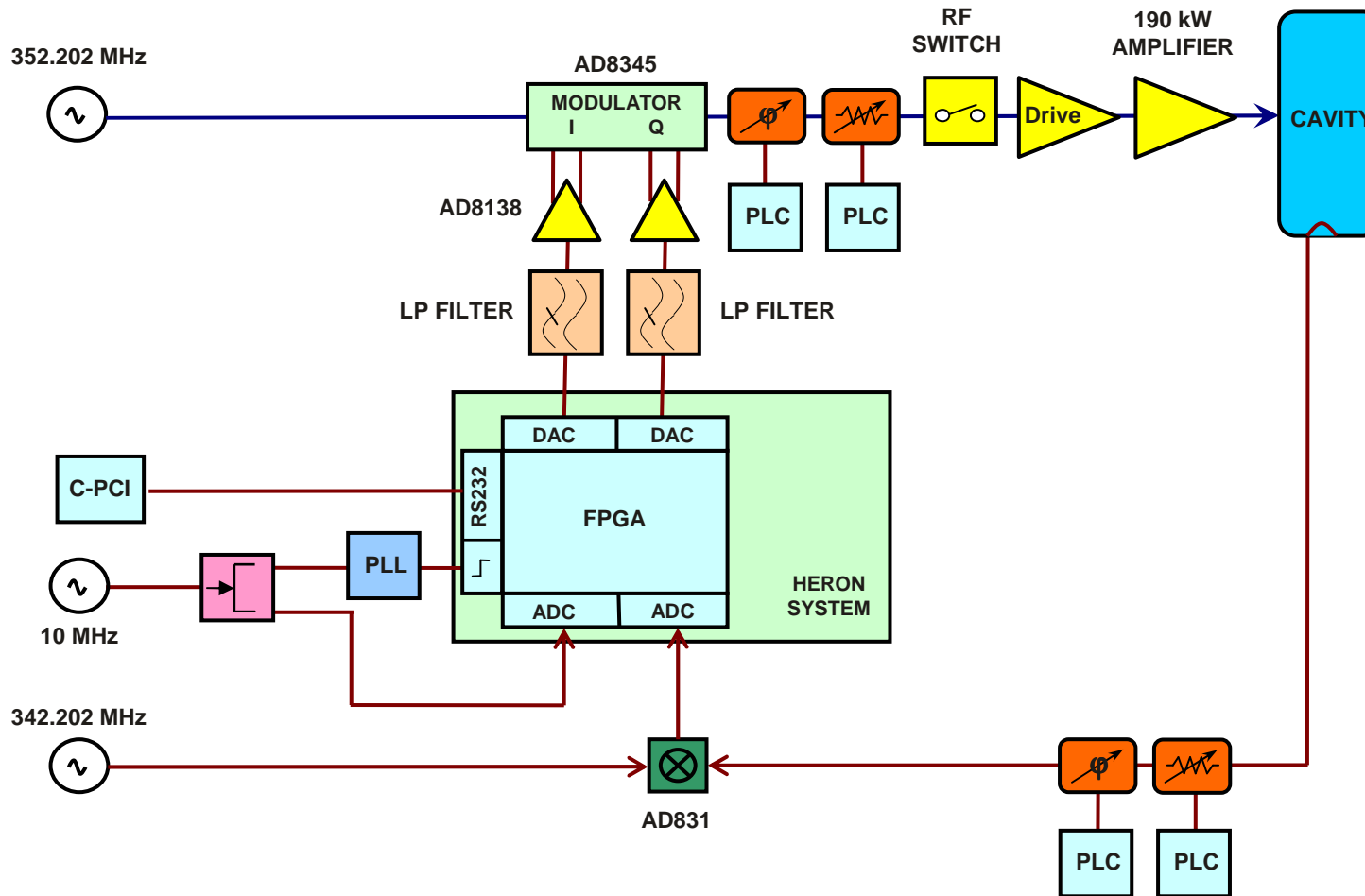

**First measured performance : 0.1 % in amplitude and 0.1° in phase  
→ to be completed in forthcoming runs**



## Summary

- Up to date, the BO and half of the SR RF systems have been commissioned
- The first operational experience is quite satisfactory : after 7000 running hours in the BO and 5000 in the SR, only 3 trips (< 1 hour), all due to human mistakes
- Special emphasis is put on the success of the solid state amplifiers, which were the most challenging part of the system; although not perturbing for the operation, in the SR 41 modules (out of 1450) suffered from a transistor failure, which corresponds to a failure rate of ~ 3 % per year (including infant mortality)
- Several laboratories (SLS, LNLS, CEA, ESRF) have expressed their intention of adopting the solid state technology “à la SOLEIL”; collaboration agreements are under elaboration and R&D is going on
- The 2nd half of the SR RF system, which is under fabrication, will be implemented in May 2008 for reaching the nominal performance (4.4 MV and 500 mA)



# Acknowledgement



## SOLEIL RF & LINAC GROUP



Fernand RIBEIRO



Patrick MARCHAND



Ti RUAN



Jean-Pierre POLLINA



Robert LOPES



Massamba DIOP



Rajesh SREEDHARAN



Marc LOUVET



Nicolas GUILLOTIN



Jean-Pierre BAETE



Helder A. DIAS



Jocelyn LABELLE



Cyril MONNOT



Moussa EL AJJOURI



Julien SALVIA

SOLEIL, CEA, CERN, ESRF, LURE

