

# Upgrade of the RF System at the ESRF \*)

*J. Jacob*

*& colleagues from ESRF RF Group*

*\*) Part of the ESRF Upgrade Program, not yet approved by the ESRF council*

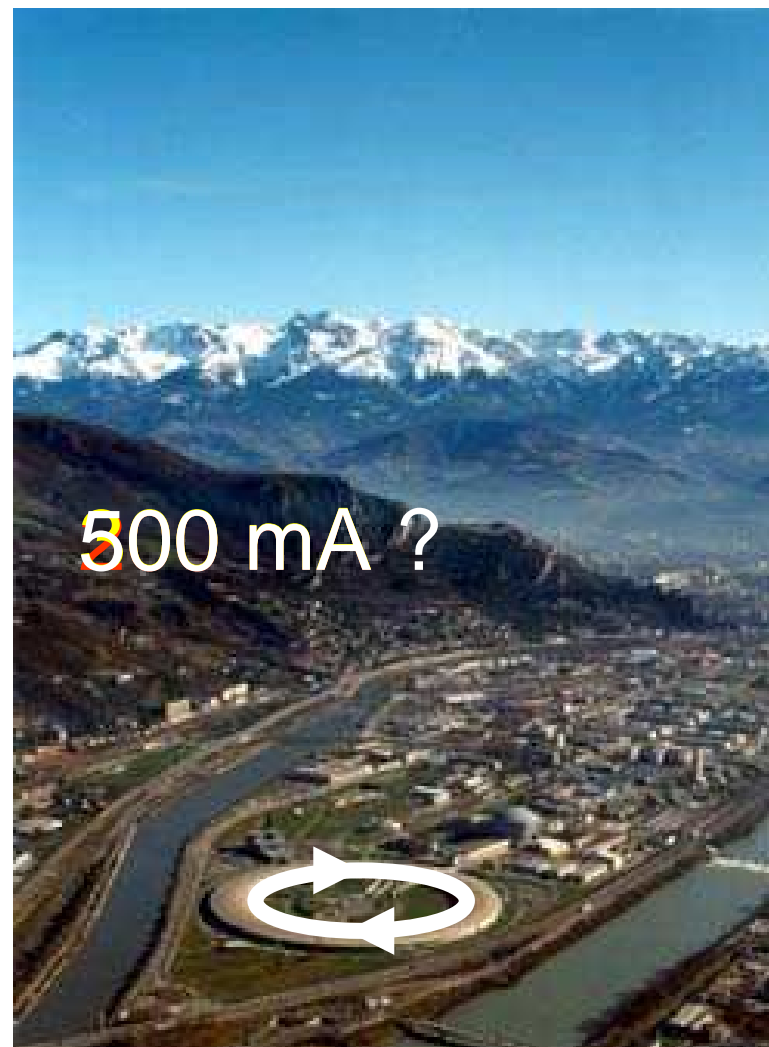

# Beam Current Increase ?



RF

- 200 mA
  - Nominal current since 1997 ➡ HOM tuning /  $T_{cav}$
- 300 mA
  - Achieved end of 2006 in MDT ➡ HOM tuning + LFB
  - Foreseen in USM for 2008/09 once replacement of all crotches will be completed
- 500 mA
  - Not scheduled for the coming accelerator upgrade
  - Subject to R&D for the coming 10 years, in preparation of a possible later upgrade
  - Any new RF design will have to be compatible with a possible increase to 500 mA

# 300 mA with existing RF system in MDT

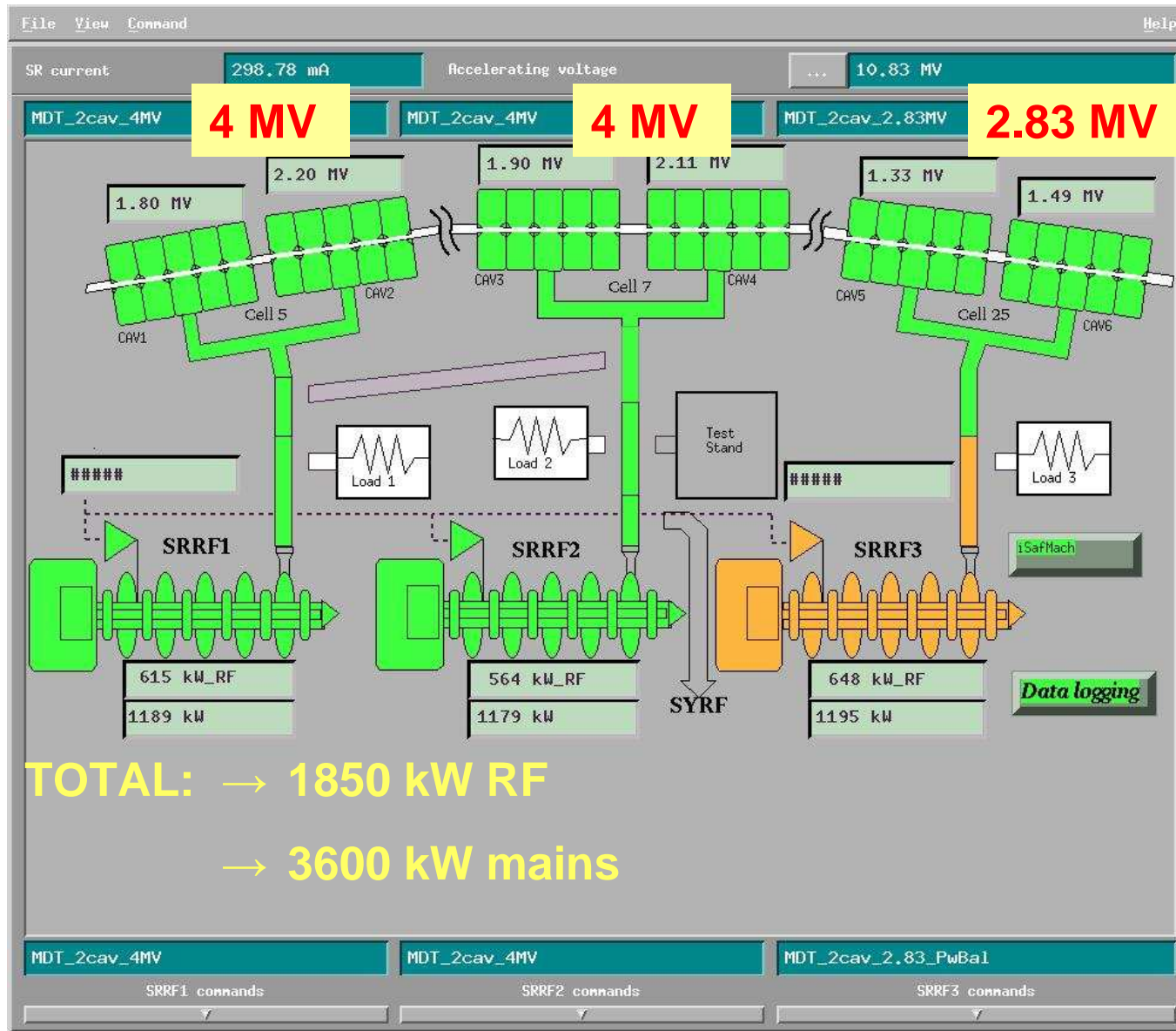

# Cavity Limitations (300 mA)



RF

- Coupling already at maximum:  $\beta = 4.4$ 
  - ⇒ RF Voltage: 9 → 11 MV against Robinson instability
  
- Cavity #5 break downs:
  - ⇒ Operation at reduced Voltage on SRRF3: 2.83 MV instead of 4 MV
  - ⇒ Problem linked to Voltage rather than beam current: yet a concern
  
- Temperature tuning of HOM:
  - Not possible to exceed 250 mA
  - Longitudinal Feedback necessary to reach 300 mA
  
- LFB limited to  $\approx 1$  ms damping time
  - ⇒ Combined LFB and HOM tuning still required to reach 300 mA
  - ⇒ Reliability for USM at 300 mA ?
  
- No further beam current increase
  - Power per Window at maximum
  - Robinson instability would require even higher voltage ⇒ additional window power !

☞ Maximum of 300 mA with existing cavities

# SR cell 25: Leak on Cavity #5 / Tuner port 2

← Quadruple

⇒ June – December 2007:  
no 300 mA in MDT

Cav #6 →

Side View

Cavity #5 not powered until replacement with spare cavity at winter shut down

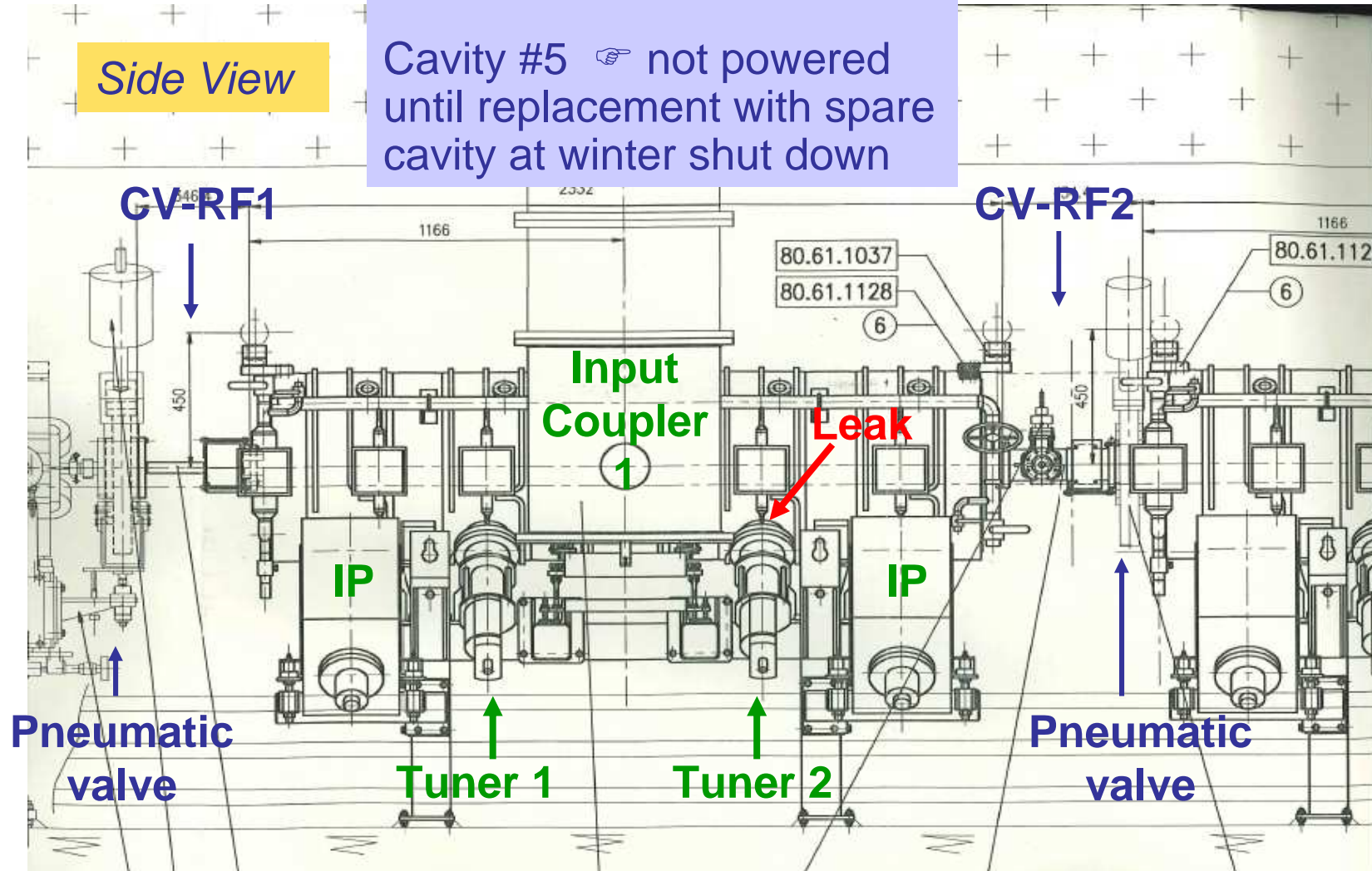

# Piston Tuner

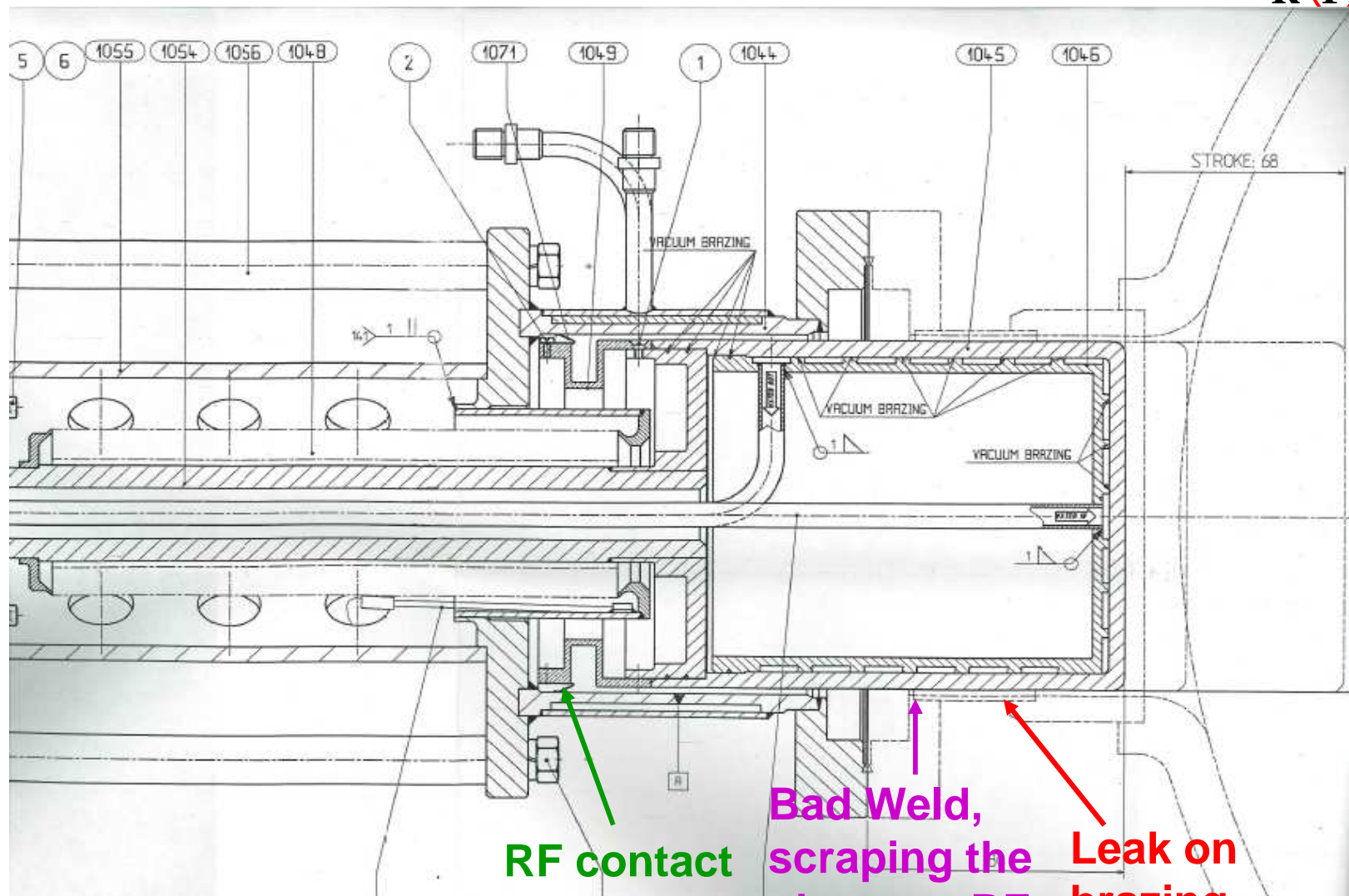

RF contact

Bad Weld,  
scraping the  
piston → RF  
heating

Leak on  
brazing

# New Cavities for the ESRF



RF

Optimized for high beam current

- At least 1 coupler per cell  
(instead of existing 2 couplers / 5-cell-cavity)  
⇒ Single cell cavities
  
- Strong HOM damping for unconditional stability
  
- Design goal including necessary margins:
  - ◇ 500 mA in terms of power
  - ◇ 1000 mA in terms of HOM damping

# Cavity comparison

HOM damped alternatives to existing ESRF 5-cell cavity:

- EU type **NC** HOM damped cavity: preferred solution for ESRF upgrade
- SOLEIL type **SC** HOM damped cavity: beam power  $\Rightarrow$  2 couplers per cell

Vnom = 9 MV									300 mA, Pbeam = 1500 kW					500 mA, Pbeam = 2500 kW				
Cavity type	R/Q [Ω]	Qo	β	Qext	price [k€/unit]	Nb	Pc-tot [kW]	Pfw [kW]	Pwind [kW]	Costs			β	Pfw [kW]	Pwind [kW]	Costs		
										Capital M€	Electr. M€, 10y	Total M€, 10y				Electr. M€, 10y	Total M€, 10y	
five-cell (2 couplers)	NC	696	38500	4.4	8750	0	6	376	1900	158	0	14.8	14.8	not possible				
-> Robinson imposes V <sub>acc</sub> = 11 MV at 300 mA																		
EU type HOM damped (1 coupler)	NC	140	30000	3.8	7895	400	18	536	2050	114	7.2	16.0	23.2	6	3036	169	23.7	30.9
							15	643	2150	143		16.8			3161	211	24.7	
							12	804	2350	196		18.3			3393	283	26.5	
SOLEIL type HOM damped (2 couplers)	SC	45	2.0E+09		80000	1000	6	0	1500	125	6	11.7	22.5		2500	208	19.5	30.3
					1 LHe liquifier / 2 cavities:	1000	3	450			3	1.8		Robinson: 11.4 MV		1.8		

Electr. Cost 60 € / MWh, mains price in 2006  
 390 k€/MW year  
**7.80 k€ / kW-rf** assuming 50% efficiency, 10 years of operation and 6500 hours/year

# Single cell **NC** HOM damped cavity



RF

## New 352 MHz Cavities for ESRF

- Unconditional stability & higher current:

400...500 mA

⇒ R&D based on BESSY design with ferrite loaded ridge waveguides for selective HOM damping

[E. Weihreter, F. Marhauser]



Cut off  
435 MHz

1<sup>st</sup> aluminum  
prototype at  
ESRF RF lab

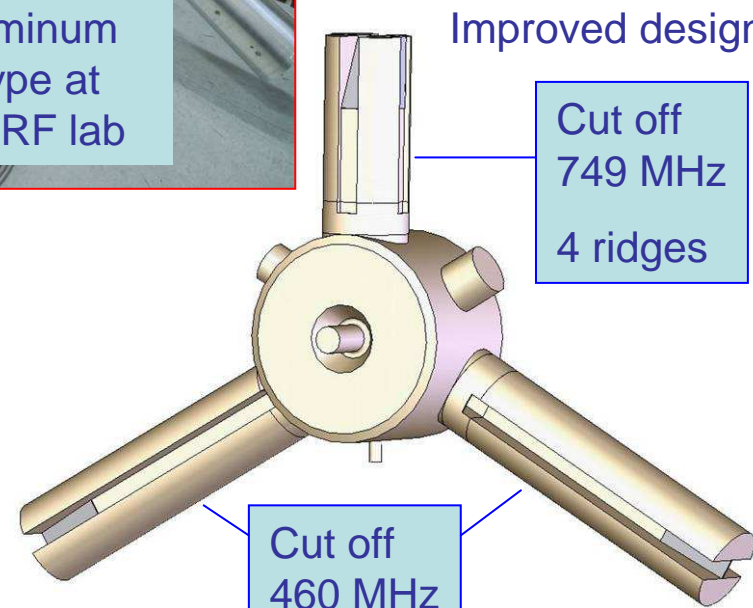

Improved design

Cut off  
749 MHz  
4 ridges

Cut off  
460 MHz

☞ Nicolas Guillotin's presentation this afternoon [N. Guillotin, V. Serrière, P. Roussely, J. Jacob]

# Multibunch – HOM driven LCBI



RF

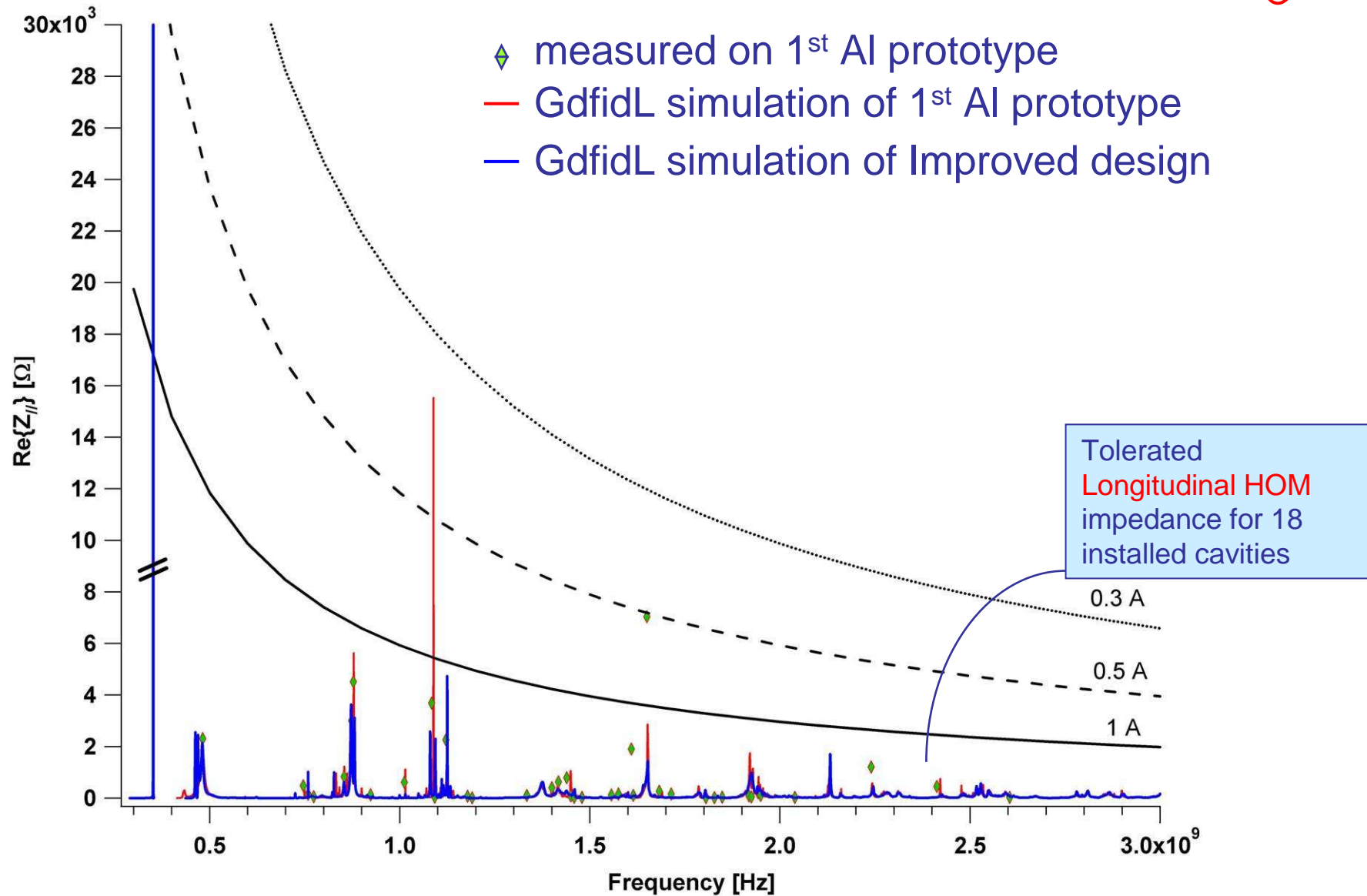

# Existing RF configuration

## Nominal configuration at 200 mA:

TRA0 on booster cavities 1,2

TRA1 on SR cavities 1,2,3,4

TRA3 on SR cavities 5,6

TRA2 available for the teststand; can be switched to replace TRA0 or TRA1 when they have to be shut down (blue dashed lines, arrows)

## 200 mA in case of TRA3 fault:

TRA1 on SR cavities 1,2

TRA2 on SR cavities 3,4

Cavities 5,6 not powered

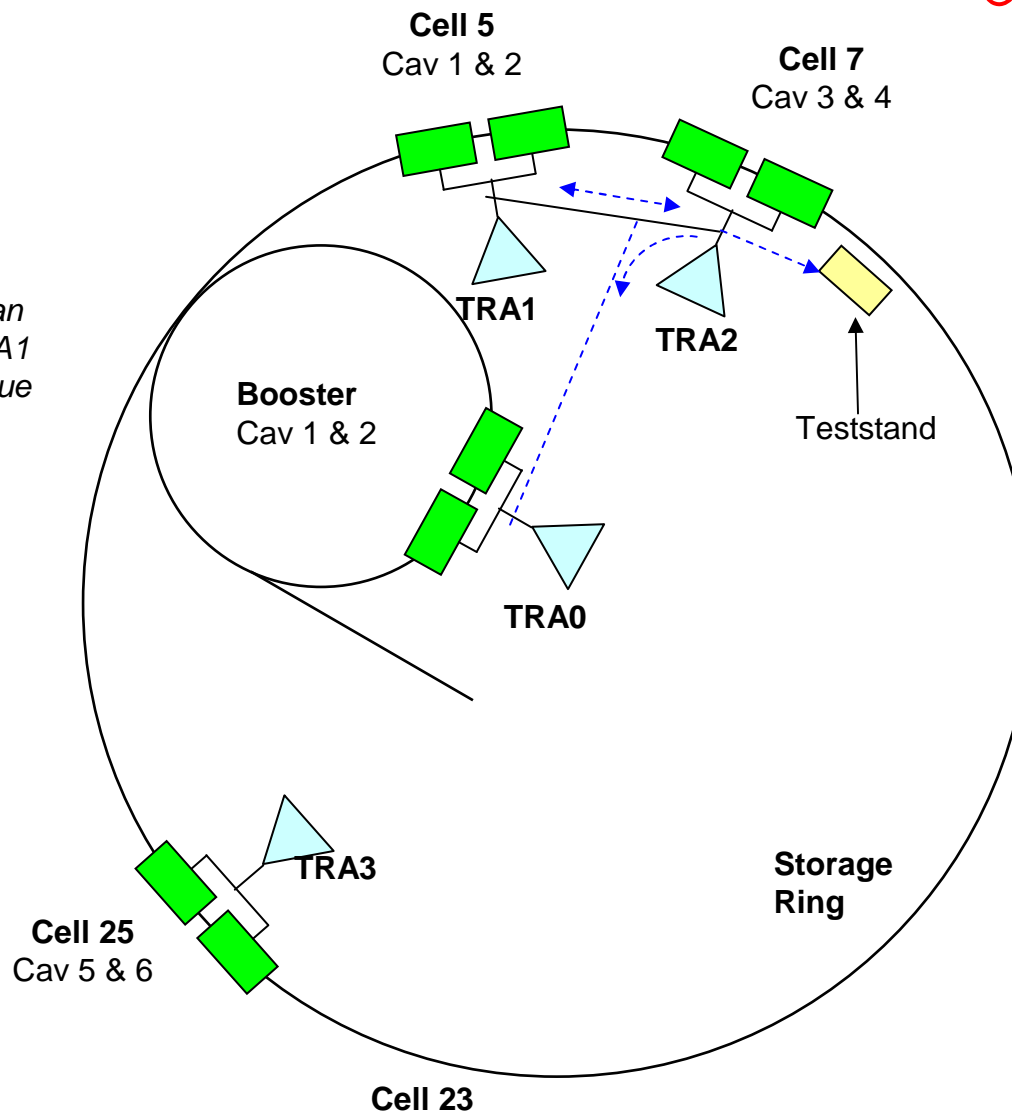

# Existing transmitter configuration for 300 mA

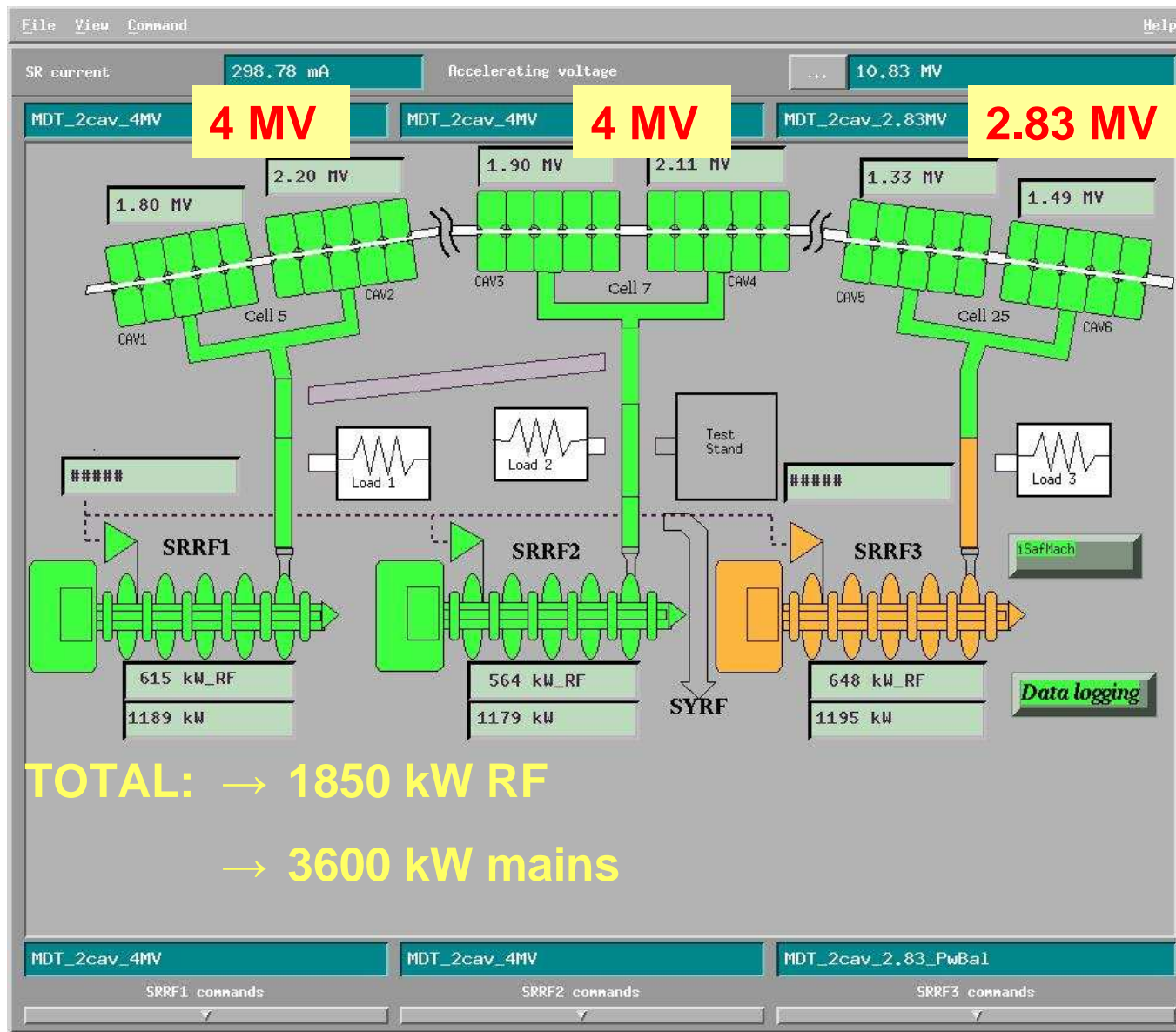

➤ **At 300 mA:** all SR transmitters are needed

- TRA1 → Cavities 1 & 2
- TRA2 → Cavities 3 & 4
- TRA3 → Cavities 5 & 6

⇒ **No spare transmitter = no safety margin**

☞ Remark: existing transmitters provide enough power for 500 mA

## ➤ Klystron transmitters

1. Safety margin would require 2 more 1.3 MW transmitters:
  - One to back up TRA0, TRA1 and TRA2
  - One to back up TRA3
  
2. Are Klystrons still a good choice for new transmitters?
  - Stability problem, difficulty in finding working point without :
    - Multipactor
    - Sidebands
  - Monopoly situation with only one supplier left
    - Risk of strong price increases
    - Risk of obsolescence
  - ESRF burning about **0.5 klystron / year**:
    - Difficulty to motivate supplier to invest for more stability
  
3. TED in principle ready to develop a 300 ... 400 kW klystron
  - Better in terms of modularity with respect to point 1 above
  - But arguments under point 2 in principle still apply

# Alternatives to Klystrons



RF

- IOTs: not for ESRF
  - Examples: ELETTRA, DIAMOND, ALBA
    - ◇ Still some problems at high power
  - Anyhow: no existing IOT at 352 MHz
- Solid State Amplifiers: PROPOSED for the ESRF upgrade
  - Successfully designed, implemented and commissioned at SOLEIL
  - Intrinsically redundant, no interruption in case of failure of an output amplifier module:
    - ◇ Not a single beam trip after 1500 hours with beam
    - ◇ Only 20 / 1400 modules broken after 1500 hours
    - ☞ Fresh statistics expected from P. Marchand in Session 2
  - Extremely modular
  - 20 dB less phase noise
  - No High Voltage
  - No Radiation
  - Note that it requires:
    - ◇ Good Quality Assurance policy at manufacturing
    - ◇ Good procurement strategy for transistors, in particular for later spare procurement

# SOLEIL 352 MHz Solid State Amplifier



RF

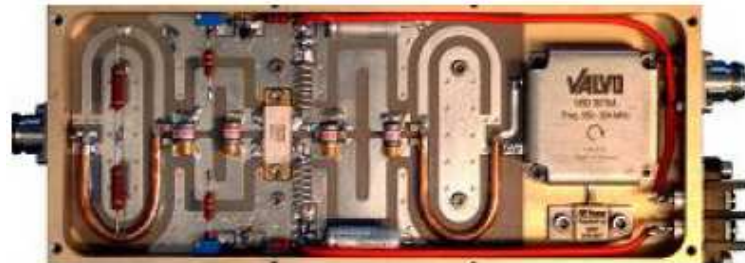

315 W module



300 V / 30 V dc-dc converter

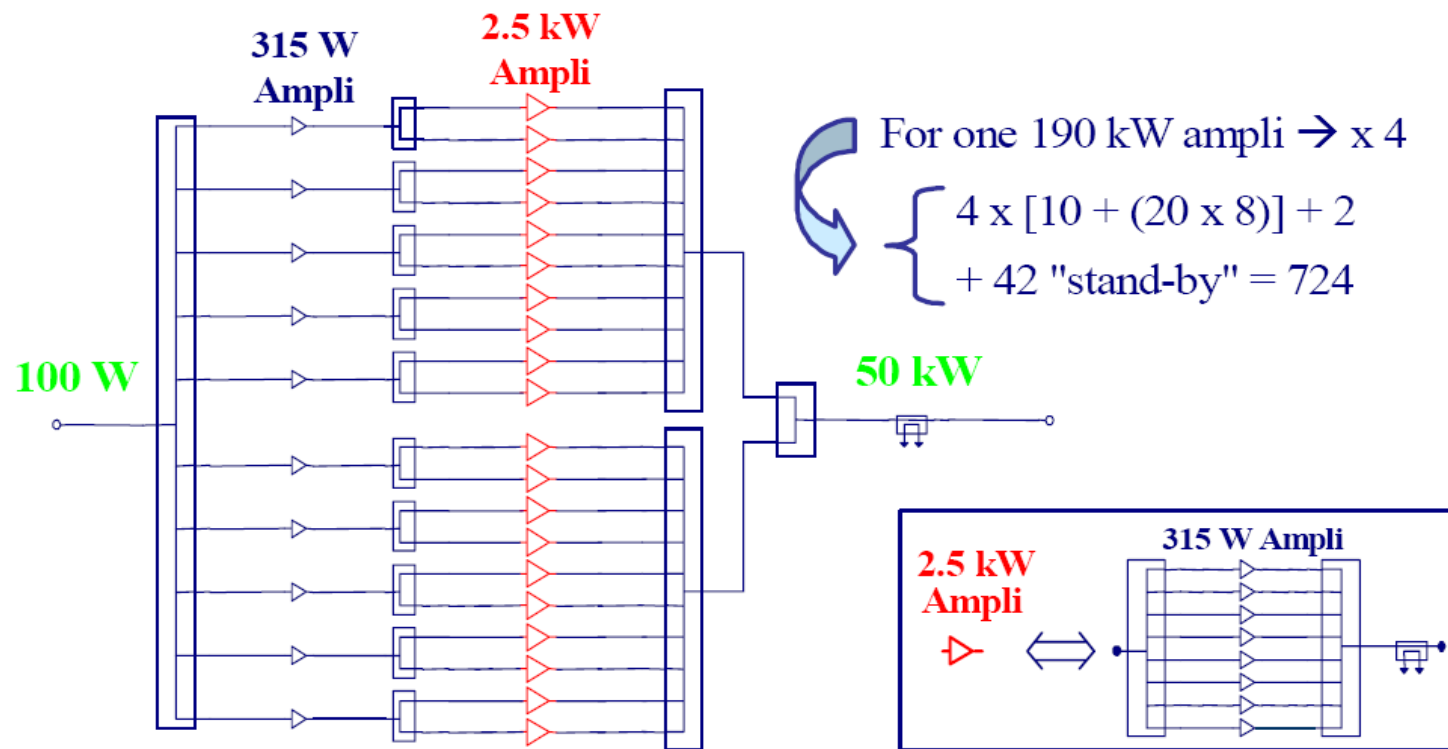

[P. Marchand, Ti Ruan et al.]

# RF Power Combiners and Splitters



RF

Power Combiner



200 kW



100 kW



25 kW



2.5 kW

Power Splitter

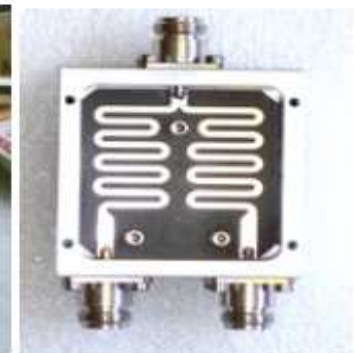

# Solid State Amplifiers at SOLEIL

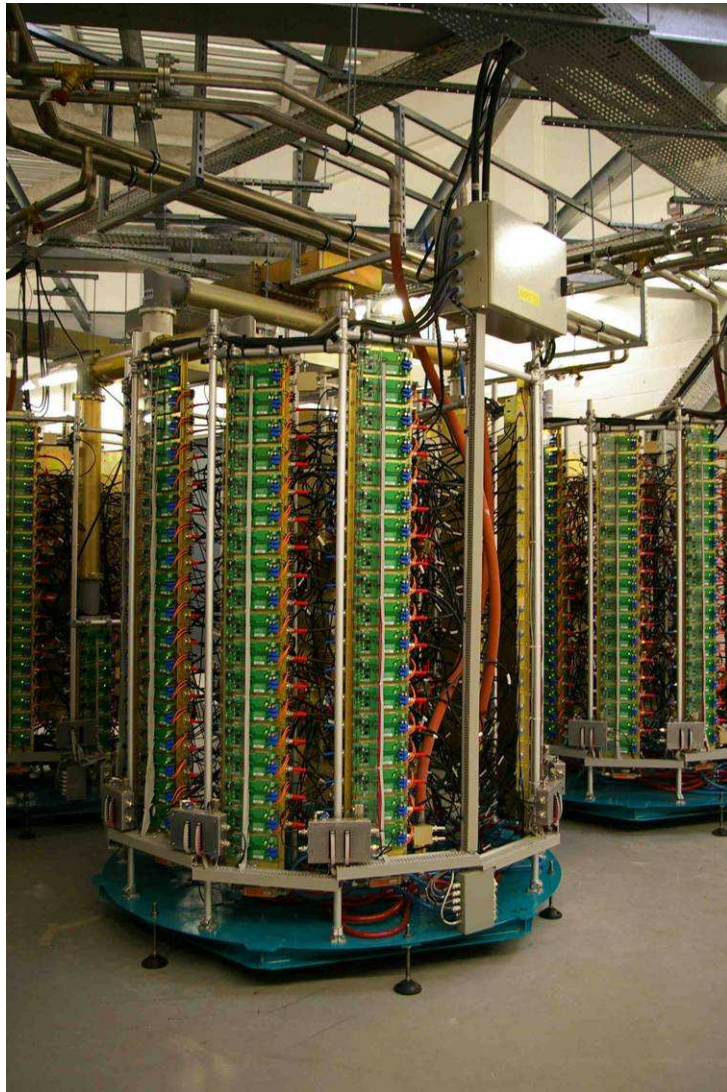

← 50 kW tower

↓ 8 towers delivering 2 x 190 kW



# Solid State Amplifiers at SOLEIL



R F

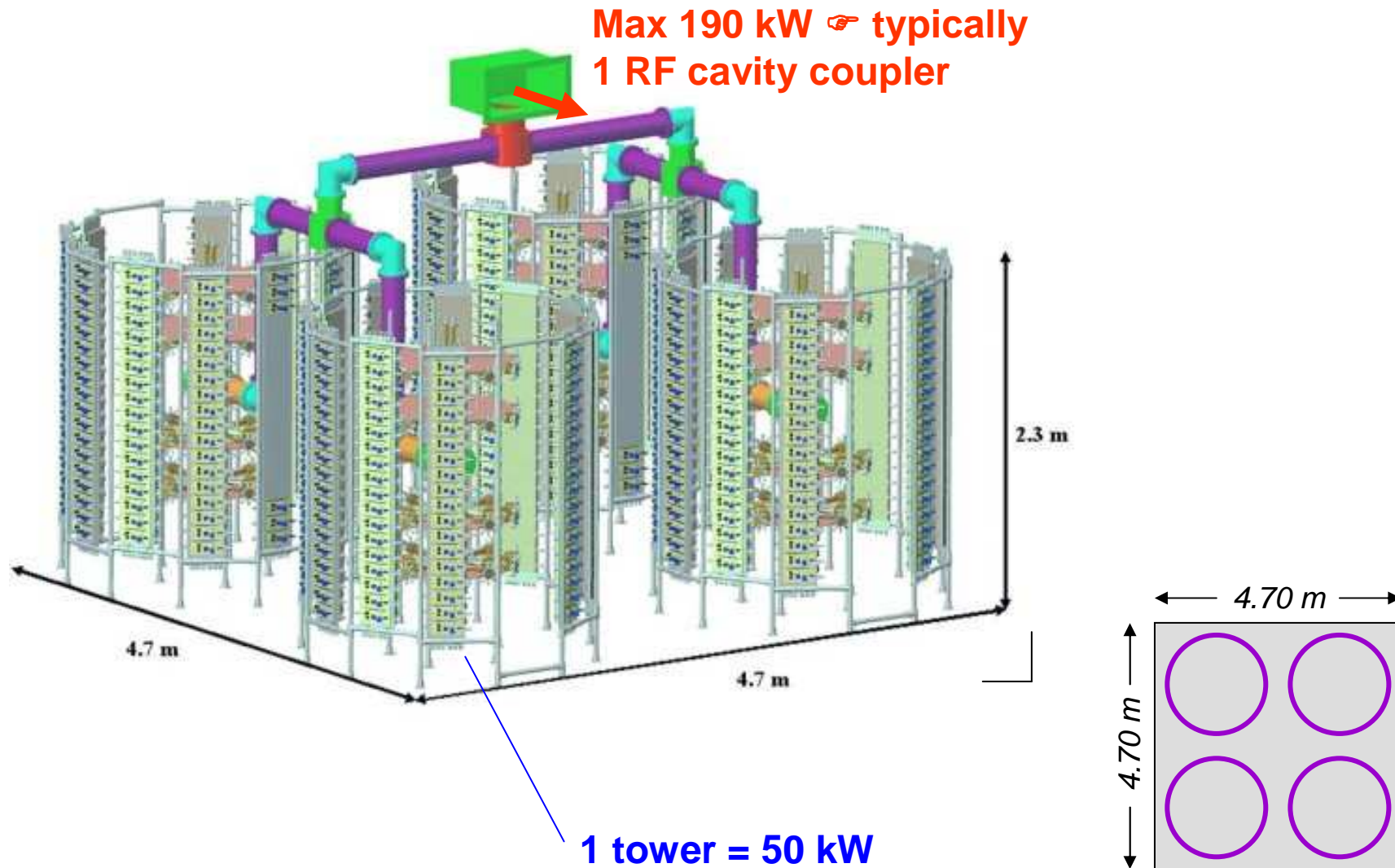

# ESRF: for 300 mA with existing 5-cell-cavities



RF

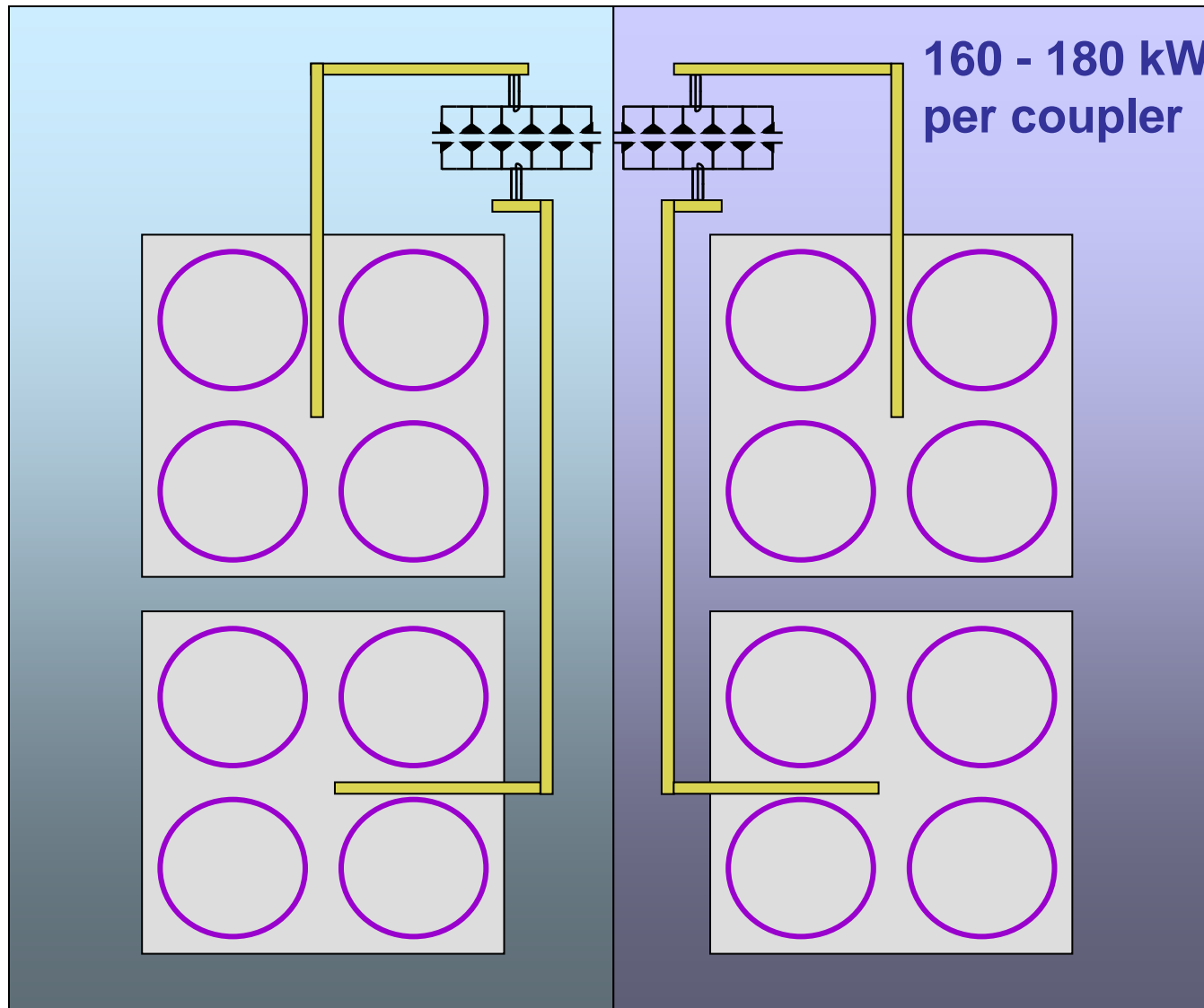



Alternative:



- **300 mA** with 5-cell cavities
  - ◇ 160 - 180 kW per coupler  $\Rightarrow$  4 towers  
(dimensioning being checked with SOLEIL)
  - ◇ 4 couplers = 16 towers per straight section
  - ◇ Replace TRA1, TRA2 and TRA3: **48 towers**
  
- **Booster**
  - ◇ Replace TRA0: **12 to 16 towers**

# Solid State Amplifiers with 18 new cavities



RF

- 300 mA with 18 single cell HOM damped cavities:
  - ◇ 120 kW per cavity  $\Rightarrow$  3 towers  
(dimensioning being checked with SOLEIL)
  - ◇ 6 cavities/cell  $\Rightarrow$  18 towers on a cell
  - ◇ TOTAL of 18 cavities  $\Rightarrow$  **54 towers**
  
- 500 mA upgrade by adding 18 towers:
  - ◇ 18 x 170 kW  $\Rightarrow$  18 x 4 towers
  - ◇ 24 towers on a cell
  - ◇ TOTAL of **72 towers**
  
- Replace TRA0

# 18 / 24 towers/cell for 300 / 500 mA with new cavities



- Smooth RF Upgrade without interruption of ESRF operation:
  - Additional space required for solid state amplifiers
  - Already existing infrastructure in the technical zones around the ring
- ⇒ Probably new satellite buildings necessary to house additional  will be defined in the coming months

# Distributed RF for more beamlines



RF

- Planned ESRF lattice upgrade:
  - 5 m straight sections → increased to 7 m
  - More space for ID's
  - Possible implementation of canted IDs → additional beam lines, however, separated only by small angle
- Extensions of experimental hall for long beam lines to develop nanoscience
  - Possible at some portions of the ring, including existing RF section in cell 7
- **RF upgrade** would allow
  - Distributed RF Layout
  - Space for **additional long beam line** in planned building extension at existing RF section
  - No problem with small canting angle

# Distributed RF for more beamlines



RF

RF cavities at low  $\beta$ :

- To avoid transverse instabilities from transverse cavity HOMs
- Low beta straight sections (odd numbers)
- Best: in the middle of a straight section

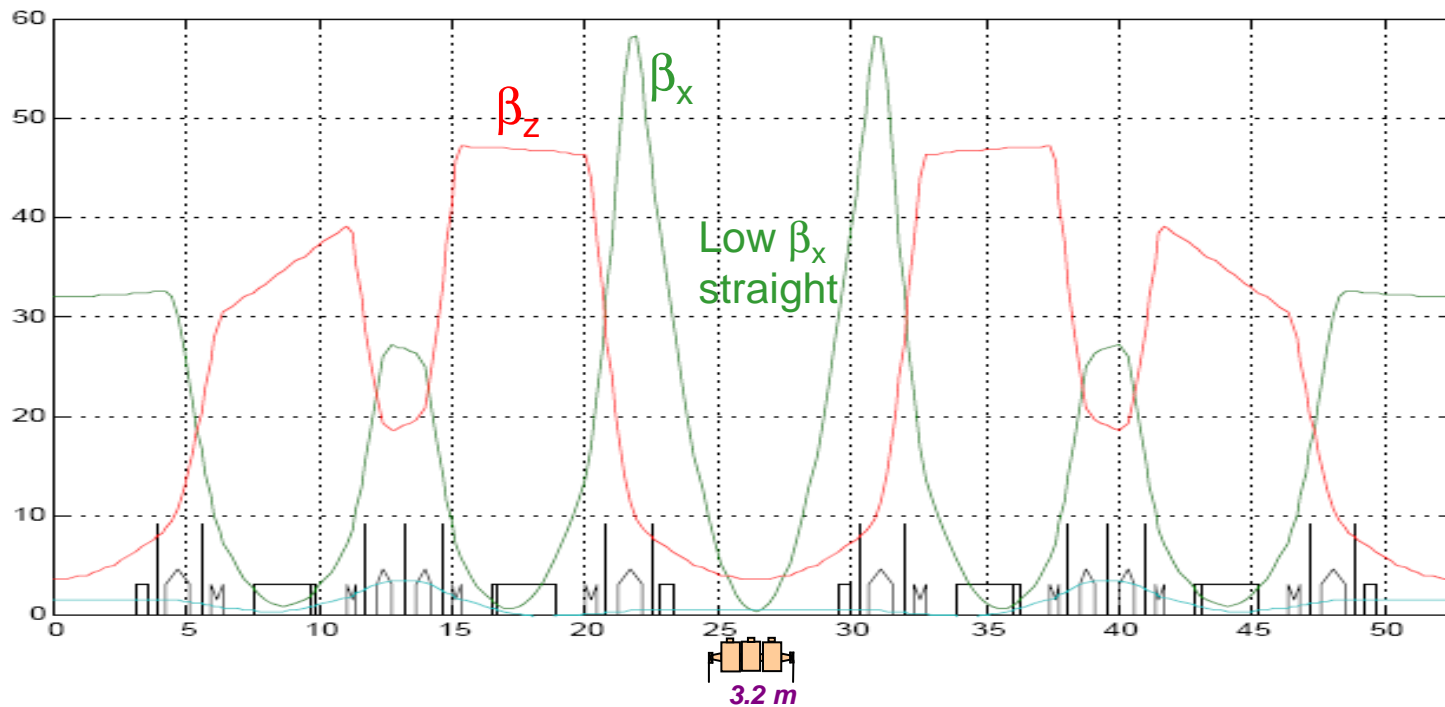

# Distributed RF for more beamlines

## Present situation

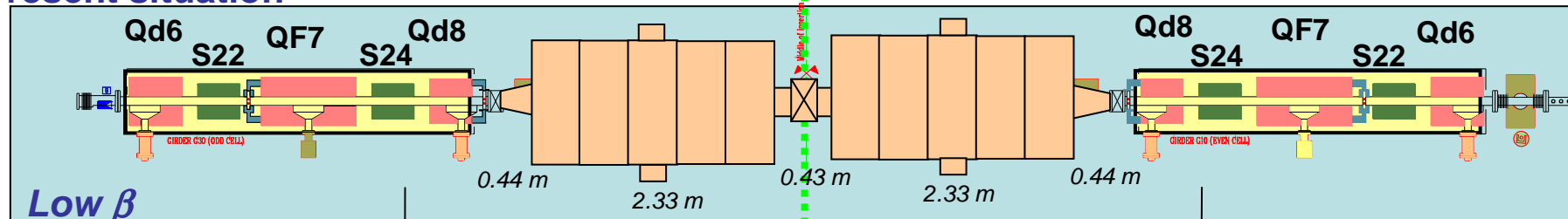

Low  $\beta$

7 m

## 7m straight with 1 existing five-cell

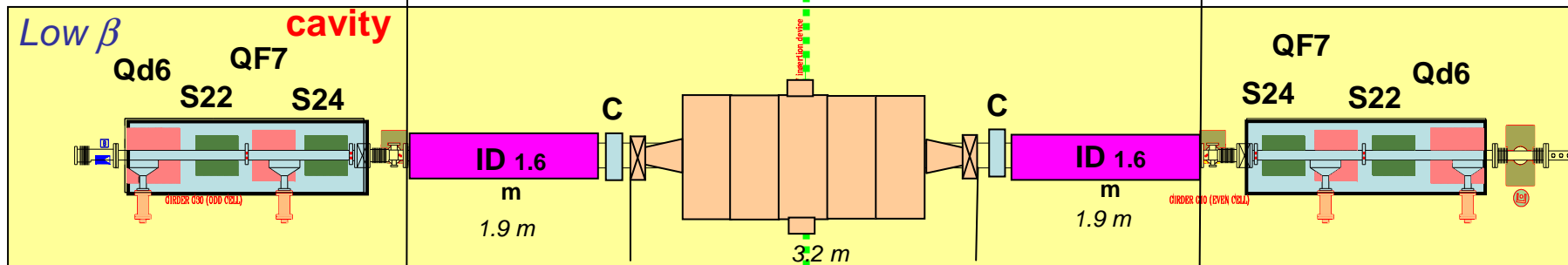

Low  $\beta$

cavity

## 7m straight with 3 new single cell

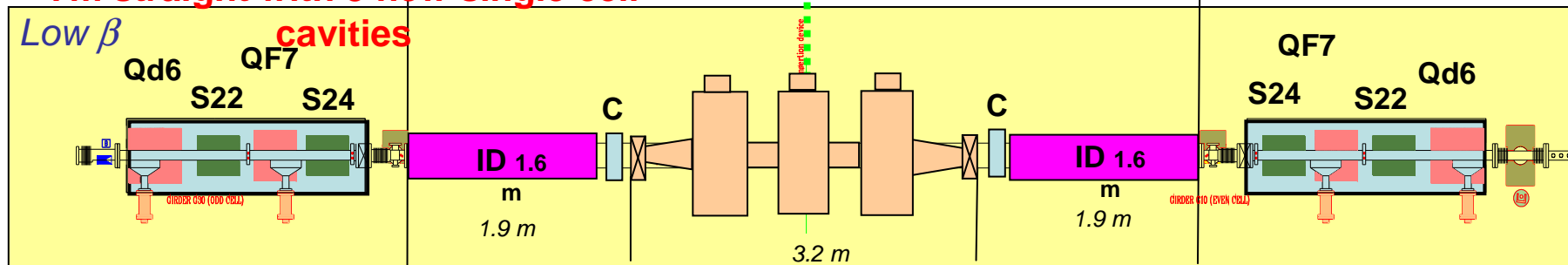

Low  $\beta$

cavities

# Application – under discussion at ESRF



RF

## Now:

- Cell 7:
  - full with RF, no ID
- Cell 23 (symmetric position):
  - 2 canted IDs

## In future:

- Cell 7
  - 7 m long
  - **2 additional IDs** + ½ RF
  - **Possible long beam line !**
- Cell 23:
  - 7 m long
  - **Keep same 2 canted IDs** + ½ RF



Allows prototyping RF upgrade on ID 23

- **Solid state amplifier** on 1 existing five-cell cavity moved from cell 7
- **3 new single cell HOM free cavities**, replacing five-cell cavity
- **Smooth and non-disruptive implementation of RF upgrade**



Could also be envisaged for other pairs of straight sections at symmetric positions:

- RF cell 5 / ID21
- RF cell 25 / ID9

# Major upgrade steps

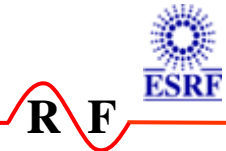

- Goal for 2008: **test one 50 kW tower**
  - Collaboration contract with SOLEIL
  - Implementation and large scale test of new generation of transistors (e.g. BLF369, ...)
  
- 2009, if ESRF upgrade program is approved: **start building up 1 prototype RF unit**
  - **1 five cell cavity**  
fed by 320 to 360 kW ➡ 8 towers of SSA

or

  - **3 new HOM damped cavities**  
fed by 360 to 400 kW ➡ 9 towers of SSA
  
- Then steadily implement the full upgrade