

Cryogenic temperatures @Tempo beamline

A new cryostat has been installed and tested on the UHV photoemission experimental station of the TEMPO beamline at Soleil :

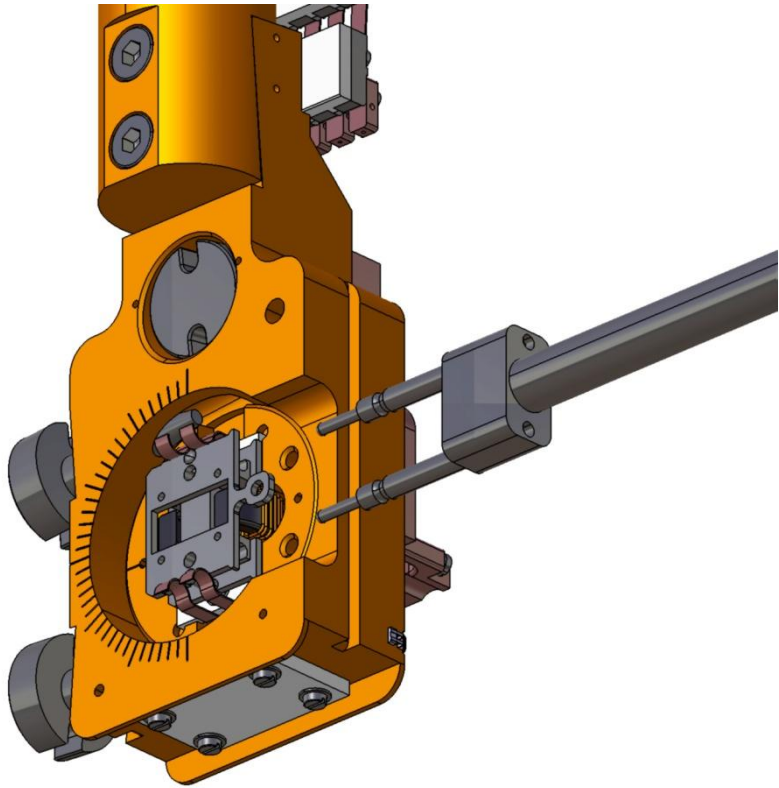

It was realised to perform photoelectron spectroscopy experiments with synchrotron radiation at low temperature. Samples can be transferred from the existing preparation chamber installed on the beamline.

The cryostat can be configured to receive two samples environments:

- Environment for semiconducting samples annealed by current flow.
- Environment to perform magnetic dichroic experiments

In both cases the sample is electrically insulated to perform sample current (Total Electron Yield) experiments and can be rotated around the axis defined by the normal to the sample surface.

The cryostat is installed on the XYZ θ OMNIAX UHV manipulator

Sample environment characteristics:

Temperature range	From minimum temperature to 400 K	
Minimum sample temperature	88 K	23 K
Azimuthal angle	Manual	
Sample transfer	Yes	
Magnetic Field	0-200 Oersted	
Intermediate Temperature	Yes (Boraelectric Heater on the sample holder)	

The cryostat can be equipped with a thermal screen to reach the lowest possible temperature when is operated with liquid Helium

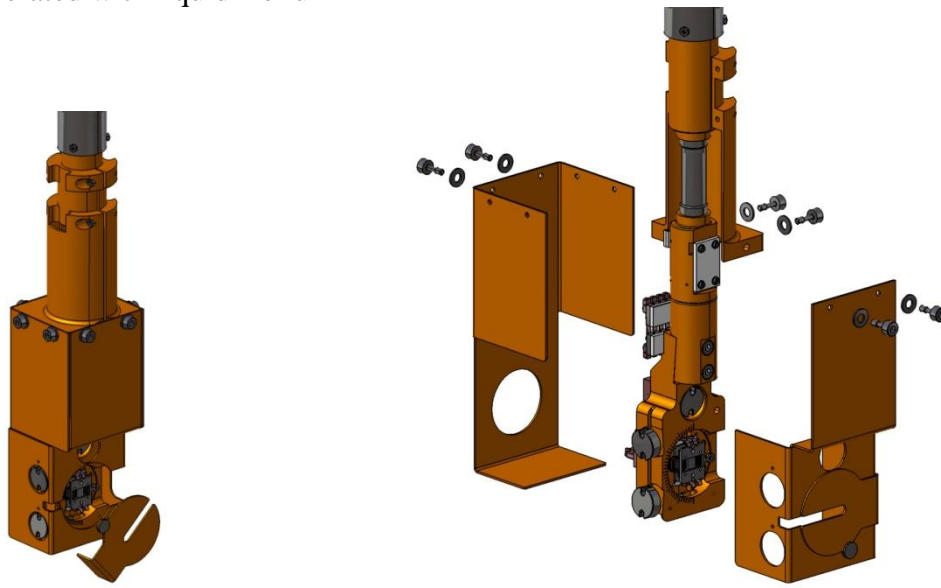

Sample Temperature Calibration.

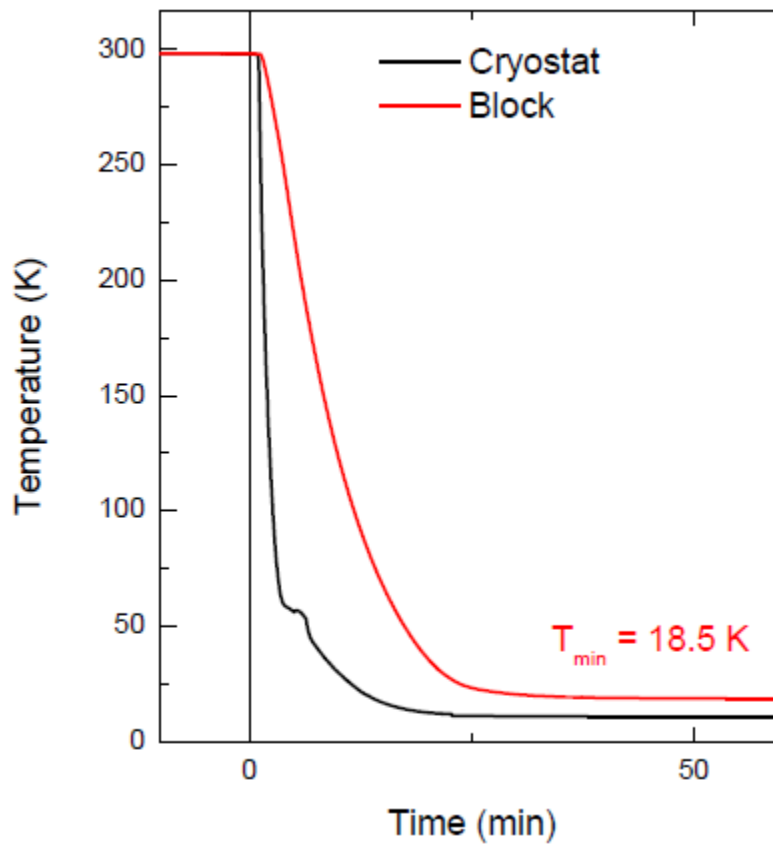

Moving from Magnetism to semiconductors sample holders.

The sample can be rotated azimuthally by rotating the whole sample environment which is built on a conical gold plated copper disk. A gate valve installed between the main chamber (UHV Photoemission) and the manipulator of the tempo beamline allows us to dismount the sample environment from the cryostat without venting the analyser chamber. The sample environment can then be replaced and only the manipulator is baked before a new experimental session.

On each disk are placed both electrical and mechanical parts of the sample environment. The two disks are shown in the following figure mounted on the cryostat head. The magnetic dichroism mounting is presented on the left side, and the semiconductor mounting on the right side.

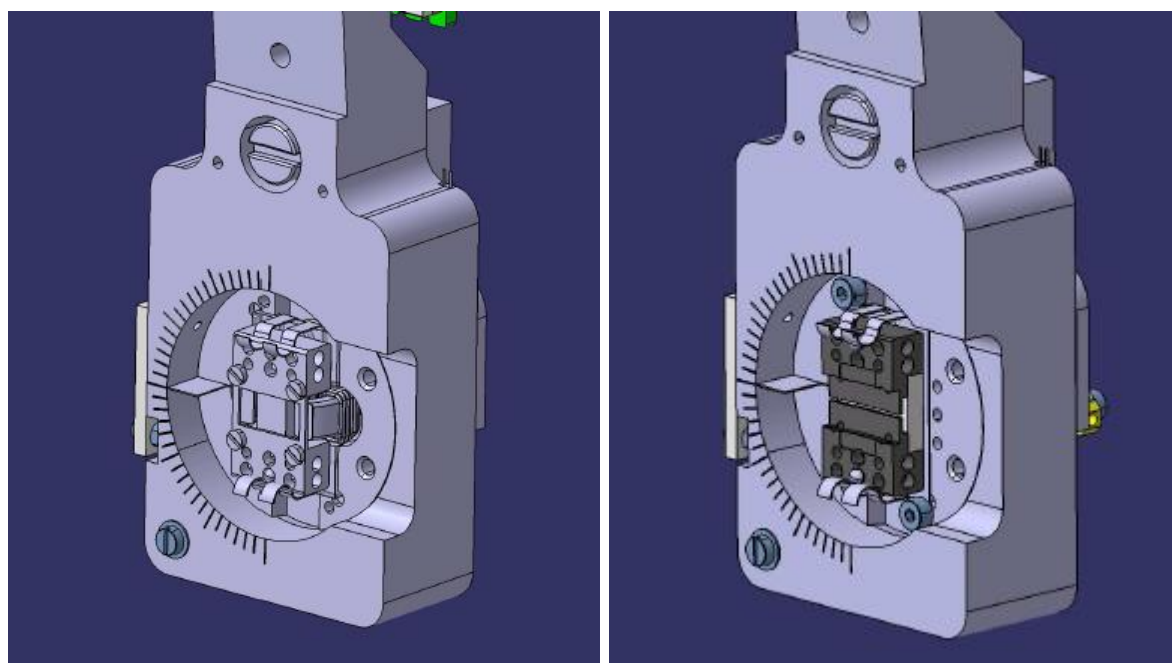

Magnetic dichroism disk on the cryostat (left) and current heating for semiconductors (right). In both cases the sample is insulated from ground for Total Electron Yield experiment.

The magnetic dichroism has two wires for magnetic field current injection and one wire connects the sample holder to a BNC feed through for sample current measurement. In the current heating disk the two wires are used for current injection. On the cryostat head are wired a boraelectric heater to set intermediate temperatures and the temperature sensor. These wiring are independent of the disk which is used.

The disk rotation is obtained using a sample transfer fork mounted on a wobble stick which can be used when the sample surface is facing the electron energy analyser.

To cool down the sample, a good thermal contact must be set between the head and the disk. The conical disk is pushed in the head block by a screw which can be operated with the standard sample transfer tool.

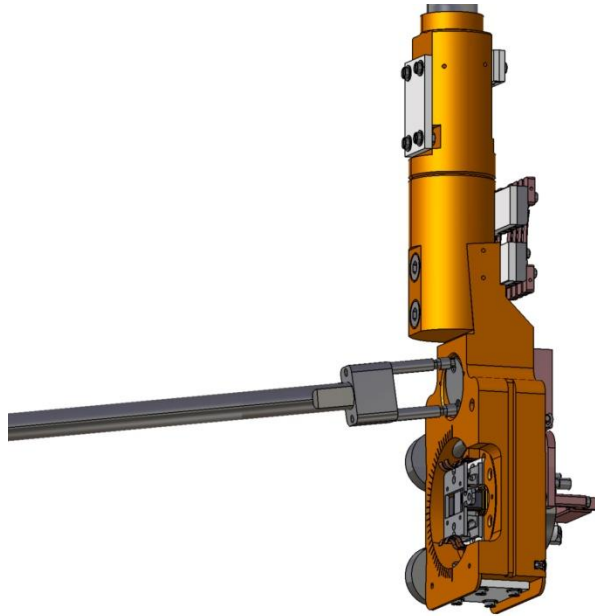

Two lateral screws are installed on the side of the head block to extract the disk after cooling before new rotations. The two screws are clockwise (top) and anticlockwise (bottom) to extract the disk.

**Before operate them, the cooling screw must de unscrewed.
They push one against the other and the cooling screw
mechanism is delicate.**